



PARTS CATALOGUE

XVS950CE (1TP1) U49

XVS950CEC (1TP2) CALIFORNIA



1N1TP-110E1

()

XVS950CE/XVS950CEC
PARTS CATALOGUE
©2013 by Yamaha Motor Co., Ltd.
1st edition, March 2013
All rights reserved.
Any reprinting or unauthorized use
without the written permission of
Yamaha Motor Co., Ltd.
is expressly prohibited.
Printed in Japan.

FOREWORD

This Parts Catalogue is related to the parts for the model(s) on the cover page. When you are ordering replacement parts, please refer to this Parts Catalogue and quote both part numbers and part names correctly.

1. Modifications or additions which have been made after the issue of the Parts Catalogue will be announced in the Parts News.

It is advisable that you make the necessary corrections to the Parts Catalogue according to the Parts News.

2. Abbreviations

The following abbreviations are used in this Parts Catalogue.

“UR” Use specified parts number.

“UN” Use as many as needed.

“AP” Alternate Parts

“LM” Locally Made (Parts need to be ordered locally)

“F#” Frame No. (Applicable machine No.)

“O/S” Over Size

3. The number of components for assembly

- Parts, which are to be supplied in an assembly, are listed with a dot (.) in front of the part name as shown below.
- The numeral appearing to the right of each component part indicates the quantity of parts for each assembly unit.

PART NO.	DESCRIPTION	Q'TY	REMARKS
2F5-83310-60	FRONT FLASHER LIGHT ASSY	2	
115-83311-60	.BULB (6V-18W)	1	

4. Applicable colours of graphics are represented in the “REMARKS” as shown below.

PART NO.	DESCRIPTION	Q'TY	REMARKS
2N4-24110-00-X5	FUEL TANK COMP.	2	MXR
3J1-24240-10	.GRAPHIC, FUEL TANK	1	FOR MXR

5. Note that the illustrations for reference in finding parts numbers are not to be used for assembling. When assembling, please use the applicable service manual.

6. The asterisk (*) before a reference number indicates modified items after the first edition.

CONTENTS

ENGINE

CYLINDER HEAD	1
CYLINDER	3
CRANKSHAFT & PISTON	4
VALVE	5
CAMSHAFT & CHAIN	6
OIL PUMP	7
OIL CLEANER	8
INTAKE 1	9
INTAKE 2	11
EXHAUST	12
CRANKCASE	14
CRANKCASE COVER 1	15
STARTER	17
CLUTCH	18
TRANSMISSION	20
SHIFT CAM & FORK	22
SHIFT SHAFT	23

CHASSIS

FRAME	24
FENDER	25
SIDE COVER	27
REAR ARM & SUSPENSION	29
STEERING	30
FRONT FORK	31
FUEL TANK	33
SEAT	36
FRONT WHEEL	37
FRONT BRAKE CALIPER	38
REAR WHEEL	39
REAR BRAKE CALIPER	41
STEERING HANDLE & CABLE	42
FRONT MASTER CYLINDER	43
STAND & FOOTREST	44
REAR MASTER CYLINDER	46
GENERATOR	48
STARTING MOTOR	49
FLASHER LIGHT	50
METER	52
HEADLIGHT	53
TAILLIGHT	54

HANDLE SWITCH & LEVER	55
ELECTRICAL 1	56
ELECTRICAL 2	58

INDEX

NUMERICAL INDEX	60
-----------------------	----

FIG. 1 CYLINDER HEAD

REF. NO.	PART NO.	DESCRIPTION	TTP1	TTP2	REMARKS
1	5S7-11101-18	CYLINDER HEAD ASSY	1	1	
2	4G0-11133-11	.GUIDE, VALVE 1	4	4	
3	93440-10085	.CIRCLIP	4	4	
4	95022-08012	.BOLT, FLANGE	1	1	
5	90430-08119	.GASKET	1	1	
6	5S7-11101-38	CYLINDER HEAD ASSY	1	1	
7	4G0-11133-11	.GUIDE, VALVE 1	4	4	
8	93440-10085	.CIRCLIP	4	4	
9	95022-08012	.BOLT, FLANGE	1	1	
10	90430-08119	.GASKET	1	1	
11	95612-08625	BOLT, STUD	4	4	
12	5S7-11181-00	GASKET, CYLINDER HEAD 1	2	2	
13	90179-12004	NUT	8	8	
14	90201-12025	WASHER, PLATE	8	8	
15	91815-16017	PIN, DOWEL	4	4	
16	90110-08065	BOLT, HEXAGON SOCKET HEAD	4	4	
17	5S7-11186-00	COVER, CYLINDER HEAD SIDE 2	4	4	
18	1TP-1114F-00	PLATE 4	1	1	
19	90110-06064	BOLT, HEXAGON SOCKET HEAD	2	2	
20	91312-06016	BOLT	18	18	
21	5S7-11196-00	GASKET, CYLINDER HEAD SIDE	4	4	
22	94701-00420	PLUG, SPARK (NGK CPR7EA)	2	2	
23	1TP-1111M-00	COVER 1	1	1	
24	1TP-1111N-00	COVER 2	1	1	
25	90480-13022	GROMMET	4	4	
26	90387-06207	COLLAR	4	4	
27	90111-06130	BOLT,HEX. SOCKET BUTTON	4	4	

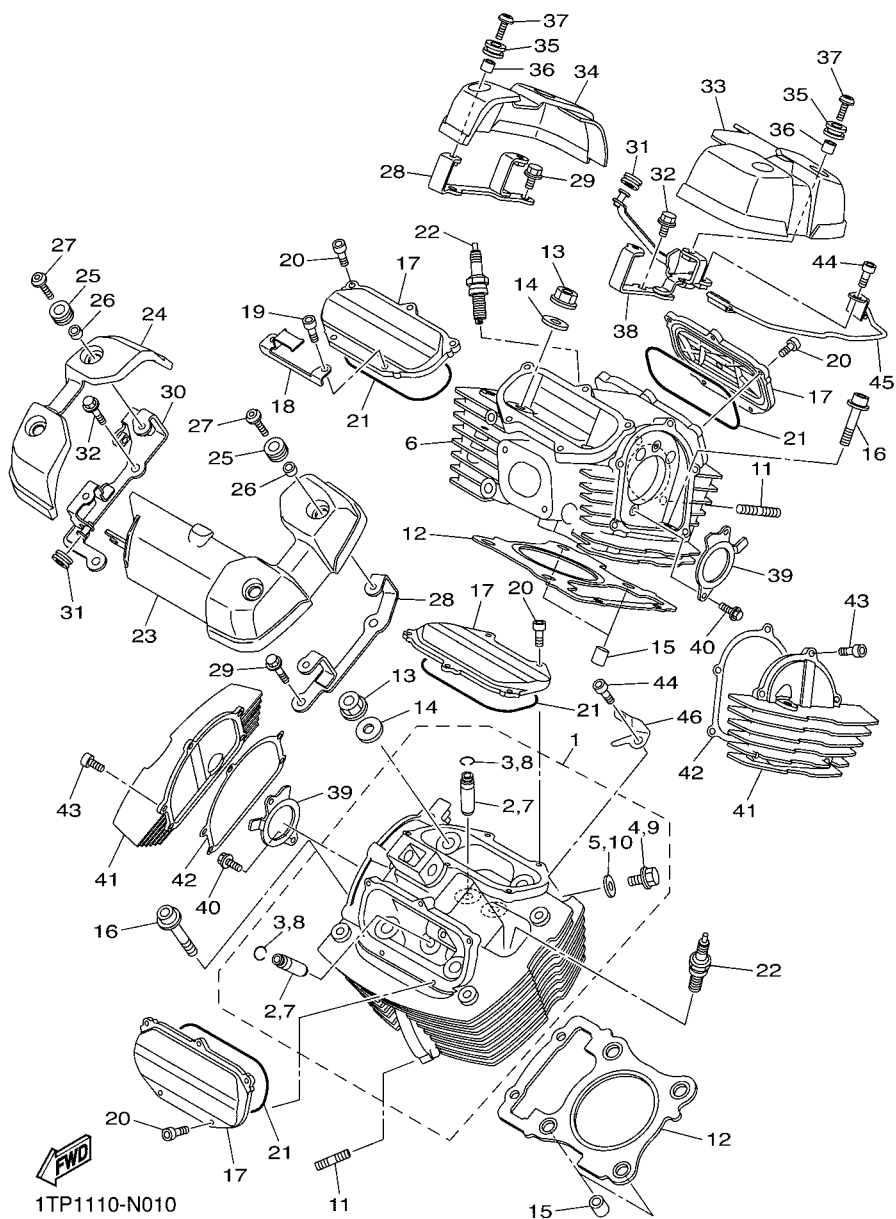
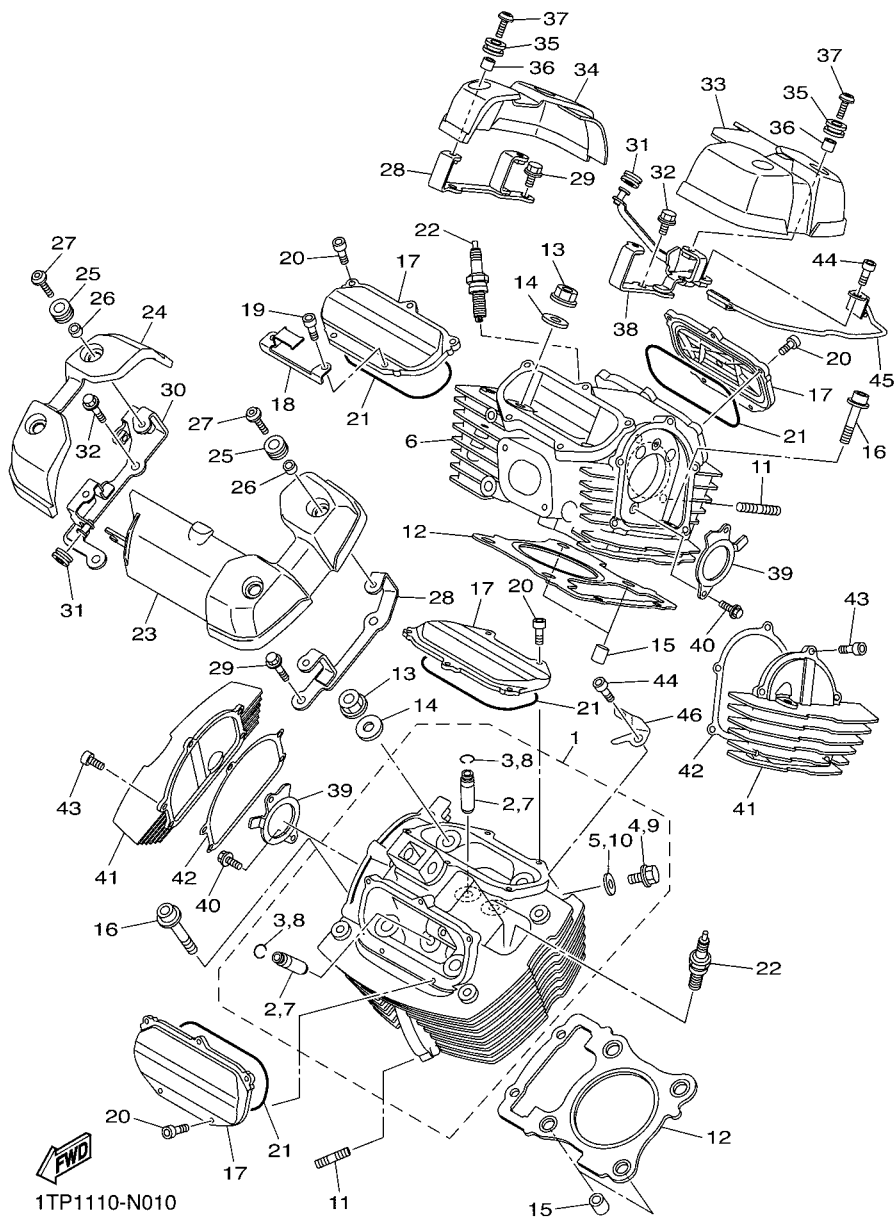

FIG. 1 CYLINDER HEAD

REF. NO.	PART NO.	DESCRIPTION			REMARKS
			1TP1	1TP2	
28	1TP-1111F-00	PLATE	2	2	
29	95822-08020	BOLT, FLANGE	4	4	
30	1TP-1112F-00	PLATE 2	1	1	
31	90480-10627	GROMMET	2	2	
32	95822-08020	BOLT, FLANGE	4	4	
33	1TP-1111P-00	COVER 3	1	1	
34	1TP-1111R-00	COVER 4	1	1	
35	90480-13022	GROMMET	4	4	
36	90387-06207	COLLAR	4	4	
37	90111-06130	BOLT,HEX. SOCKET BUTTON	4	4	
38	1TP-1113F-00	PLATE 3	1	1	
39	5S7-1111F-00	PLATE	2	2	
40	95022-06012	BOLT, FLANGE	4	4	
41	5S7-11185-00	COVER, CYLINDER HEAD SIDE 3	2	2	
42	5S7-11195-00	GASKET	2	2	
43	90110-06274	BOLT, HEXAGON SOCKET HEAD	10	10	
44	91312-08016	BOLT	3	3	
45	1TP-11152-00	BRACKET, CYLINDER HEAD COVER	1	1	
46	1TP-24364-00	STAY	1	1	



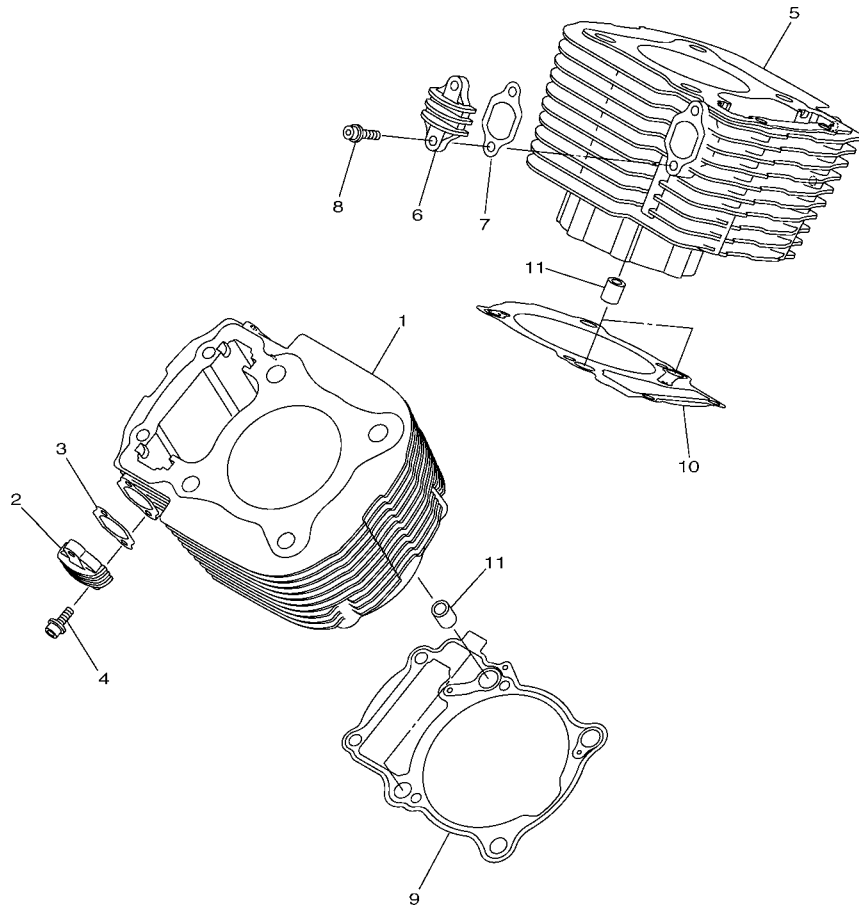
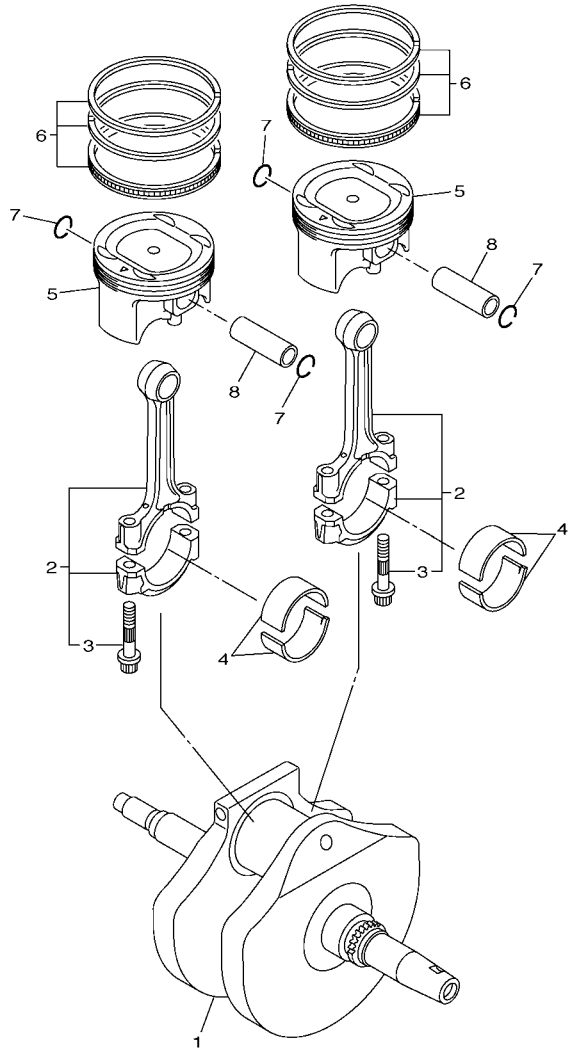

FIG. 2 CYLINDER

REF. NO.	PART NO.	DESCRIPTION	TTP1	TTP2	REMARKS
1	1TP-11311-00	CYLINDER 1	1	1	
2	5S7-12215-00	CAP, TENSIONER CASE	1	1	
3	5S7-12214-00	GASKET	1	1	
4	90109-06015	BOLT	2	2	
5	1TP-11311-00	CYLINDER 1	1	1	
6	5S7-12215-00	CAP, TENSIONER CASE	1	1	
7	5S7-12214-00	GASKET	1	1	
8	90109-06015	BOLT	2	2	
9	5S7-11351-00	GASKET, CYLINDER	1	1	
10	5S7-11352-00	GASKET, CYLINDER 2	1	1	
11	99530-08016	PIN, DOWEL	4	4	



5S71110-H020



5S71110-H030

FIG. 3 CRANKSHAFT & PISTON

REF. NO.	PART NO.	DESCRIPTION	TTP1	TTP2		REMARKS
1	5S7-11411-00	CRANKSHAFT	1	1		
2	5S7-11650-00	CONNECTING ROD ASSY	2	2		
3	5YU-11654-00	.BOLT, CONNECTING ROD	2	2		
4	5YU-11656-10	PLANE BEARING, CONNECTING ROD	4	4		UR BLACK
	5YU-11656-20	PLANE BEARING, CONNECTING ROD	4	4		UR BROWN
	5YU-11656-30	PLANE BEARING, CONNECTING ROD	4	4		UR GREEN
5	5S7-11631-01	PISTON (STD)	2	2		
6	5S7-11603-00	PISTON RING SET (STD)	2	2		
7	93450-22146	CIRCLIP	4	4		
8	5PS-11633-00	PIN, PISTON	2	2		
<hr/>						
<hr/>						
<hr/>						
<hr/>						
<hr/>						
<hr/>						
<hr/>						
<hr/>						
<hr/>						
<hr/>						

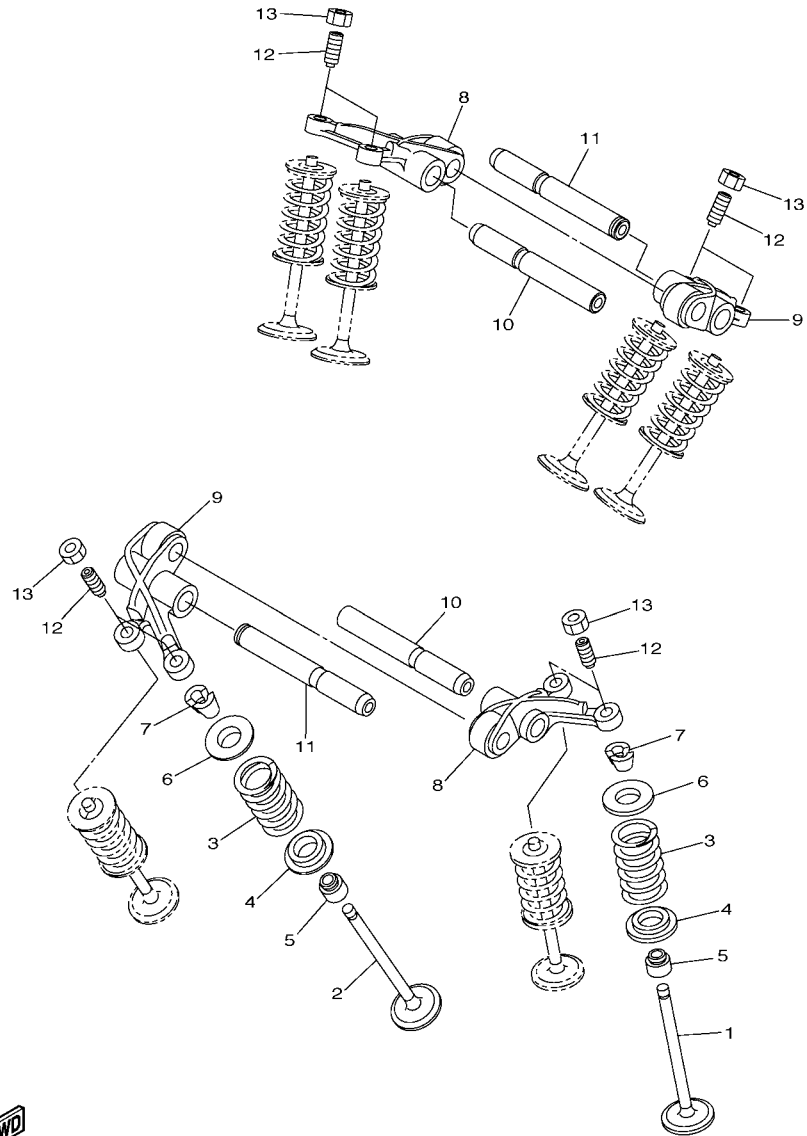

5S71110-H040

FIG. 4 VALVE

REF. NO.	PART NO.	DESCRIPTION	TTP1	TTP2	REMARKS
1	5S7-12111-00	VALVE, INTAKE	4	4	
2	5S7-12121-00	VALVE, EXHAUST	4	4	
3	5S7-12113-00	SPRING, VALVE INNER	8	8	
4	3YF-12116-00	SEAT, VALVE SPRING	8	8	
5	5H0-12119-00	SEAL, VALVE STEM	8	8	
6	3YF-12117-01	RETAINER, VALVE SPRING	8	8	
7	4G0-12118-00	LOCK, VALVE SPRING RETAINER	16	16	
8	5S7-12151-00	ARM, VALVE ROCKER	2	2	
9	5S7-12161-00	ARM, VALVE ROCKER 2	2	2	
10	5S7-12146-00	SHAFT, ROCKER	2	2	
11	5S7-12156-00	SHAFT, ROCKER 2	2	2	
12	4X7-12159-00	SCREW, VALVE ADJUSTING	8	8	
13	90170-08173	NUT	8	8	

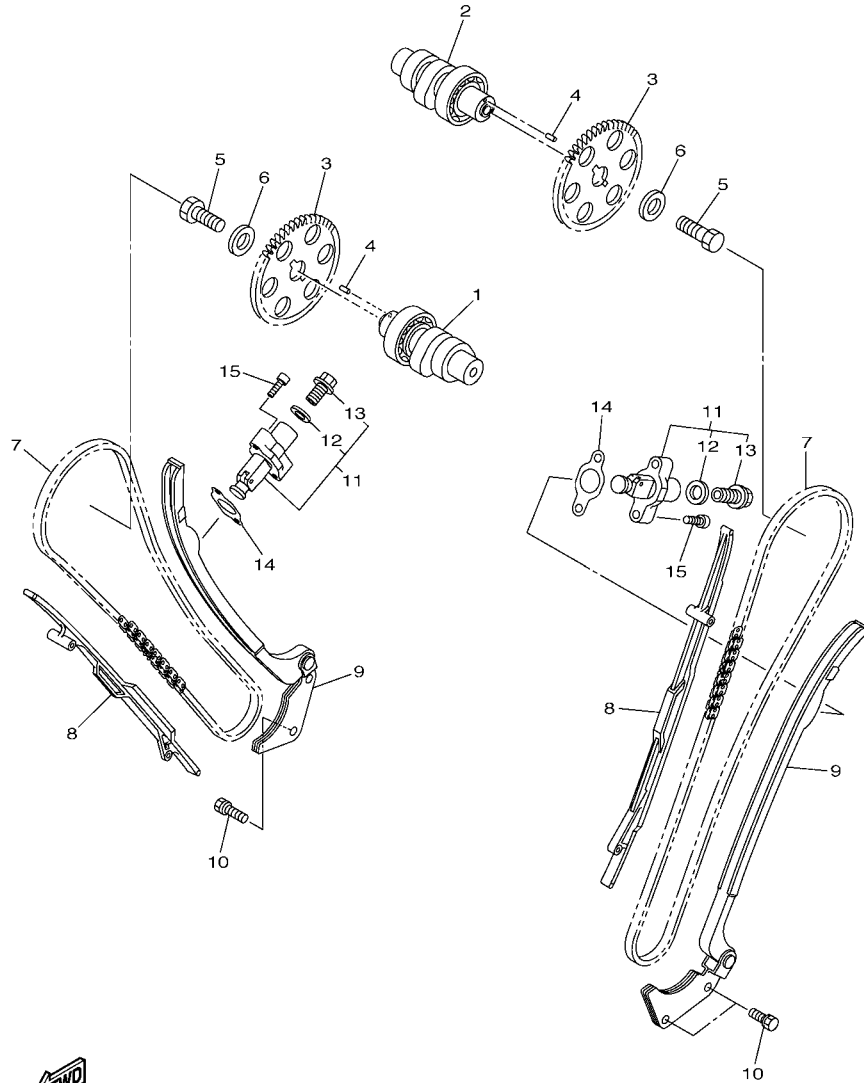

5S71110-H050

FIG. 5 CAMSHAFT & CHAIN

REF. NO.	PART NO.	DESCRIPTION	TTP1	TTP2	REMARKS
1	5S7-12170-10	CAMSHAFT ASSY 1	1	1	
2	5S7-12180-10	CAMSHAFT ASSY 2	1	1	
3	5S7-12176-00	SPROCKET, CAM CHAIN	2	2	
4	93604-12037	PIN, DOWEL	2	2	
5	90101-10016	BOLT	2	2	
6	90201-10591	WASHER, PLATE	2	2	
7	94591-59132	CHAIN	2	2	
8	5S7-12231-00	GUIDE, STOPPER 1	2	2	
9	3D8-12241-00	GUIDE, STOPPER 2	2	2	
10	90119-06173	BOLT, WITH WASHER	4	4	
11	31G-12210-01	TENSIONER ASSY, CAM CHAIN	2	2	
12	31G-12214-00	.GASKET	1	1	
13	31G-12222-00	.PLUG	1	1	
14	3GD-12213-00	GASKET, TENSIONER CASE	2	2	
15	91314-06025	BOLT, HEXAGON SOCKET HEAD	4	4	

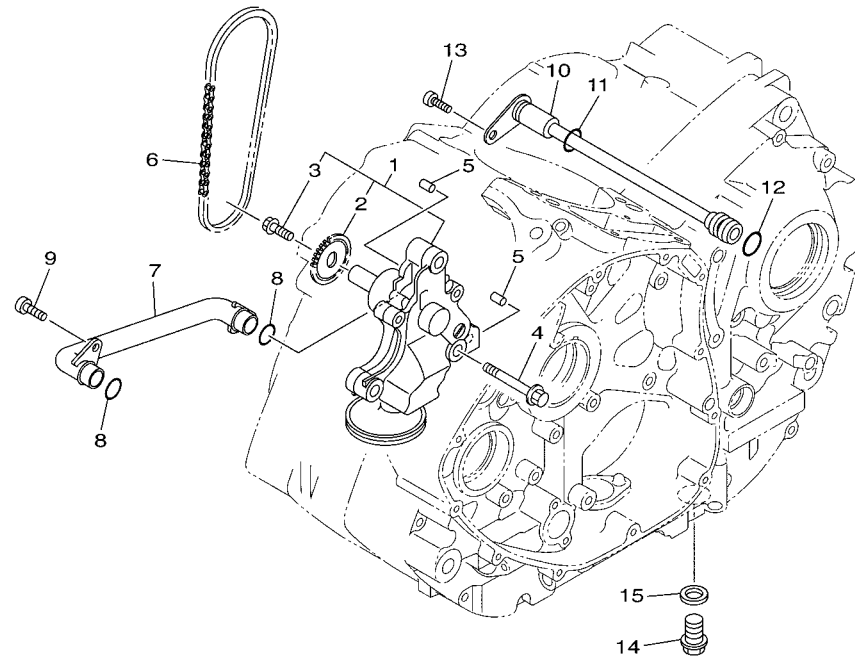

FIG. 6 OIL PUMP

REF. NO.	PART NO.	DESCRIPTION	TTP1	TTP2			REMARKS
1	5S7-13300-00	OIL PUMP ASSY	1	1			
2	3D8-13355-00	.SPROCKET, DRIVEN	1	1			
3	90105-06066	.BOLT, FLANGE	1	1			
4	95812-08045	BOLT, FLANGE	3	3			
5	99530-08012	PIN, DOWEL	2	2			
6	94580-25062	CHAIN (DID25 62L)	1	1			
7	3D8-13416-00	PIPE, OIL 1	1	1			
8	93210-14003	O-RING	2	2			
9	90110-06161	BOLT, HEXAGON SOCKET HEAD	2	2			
10	5S7-13171-00	PIPE, DELIVERY 2	1	1			
11	93210-09165	O-RING	1	1			
12	93210-06564	O-RING	1	1			
13	90110-06161	BOLT, HEXAGON SOCKET HEAD	1	1			
14	90340-14132	PLUG, STRAIGHT SCREW	1	1			
15	214-11198-01	GASKET	1	1			



5S71110-H060

FIG. 7 OIL CLEANER

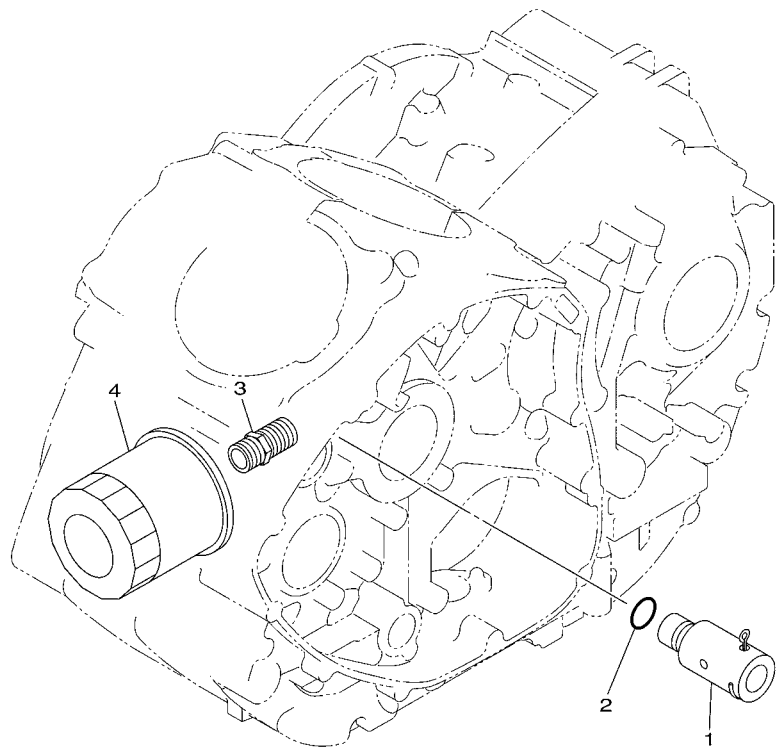

REF. NO.	PART NO.	DESCRIPTION	TTP1	TTP2		REMARKS
1	3D8-13490-00	RELIEF VALVE ASSY	1	1		
2	93210-10096	O-RING	1	1		
3	90401-20008	BOLT, UNION	1	1		
4	5GH-13440-50	ELEMENT ASSY, OIL CLEANER	1	1		



26S7110-K070

FIG. 8 INTAKE 1

REF. NO.	PART NO.	DESCRIPTION	1TP1	1TP2	REMARKS
1	1TP-13590-00	CARBURETOR JOINT ASSY	1	1	
2	5S7-13761-00	.INJECTOR	2	2	
3	5PS-14147-00	..O-RING	1	1	
4	8FP-13556-00	.RUBBER, INJECTOR	2	2	
5	1TP-13930-00	.PIPE INLET ASSEMBLY	1	1	
6	91312-05010	.BOLT	2	2	
7	90110-06168	.BOLT, HEXAGON SOCKET HEAD	4	4	
8	1TP-13906-00	.REGULATOR, PRESSURE	1	1	
9	5S7-13769-00	..O-RING	1	1	
10	5S7-13586-00	JOINT, CARBURETOR 1	2	2	
11	91312-06020	BOLT	4	4	
12	90450-54006	HOSE CLAMP ASSY	2	2	
13	1TP-13750-00	THROTTLE BODY ASSY	1		
	1TP-13750-10	THROTTLE BODY ASSY		1	
14	8GL-85885-00	.THROTTLE SENSOR ASSY	1	1	
15	4KM-24453-00	.SCREW	2	2	
16	3D8-14104-00	.AIR SCREW SET	2	2	
17	895-14169-00	.CAP	1	1	
18	8A7-14139-00	.CLIP, PIPE	1	1	
19	3D8-14467-00	SEAL	1	1	
20	91312-06020	BOLT	3	3	
21	1TP-13895-00	HOSE, AIR	1	1	
22	90467-07093	CLIP	1	1	
23	90467-08092	CLIP	1	1	
24	5S7-82380-00	SENSOR, PRESSURE	1	1	
25	97002-05020	BOLT	1	1	
26	92902-05600	WASHER, PLATE	1	1	

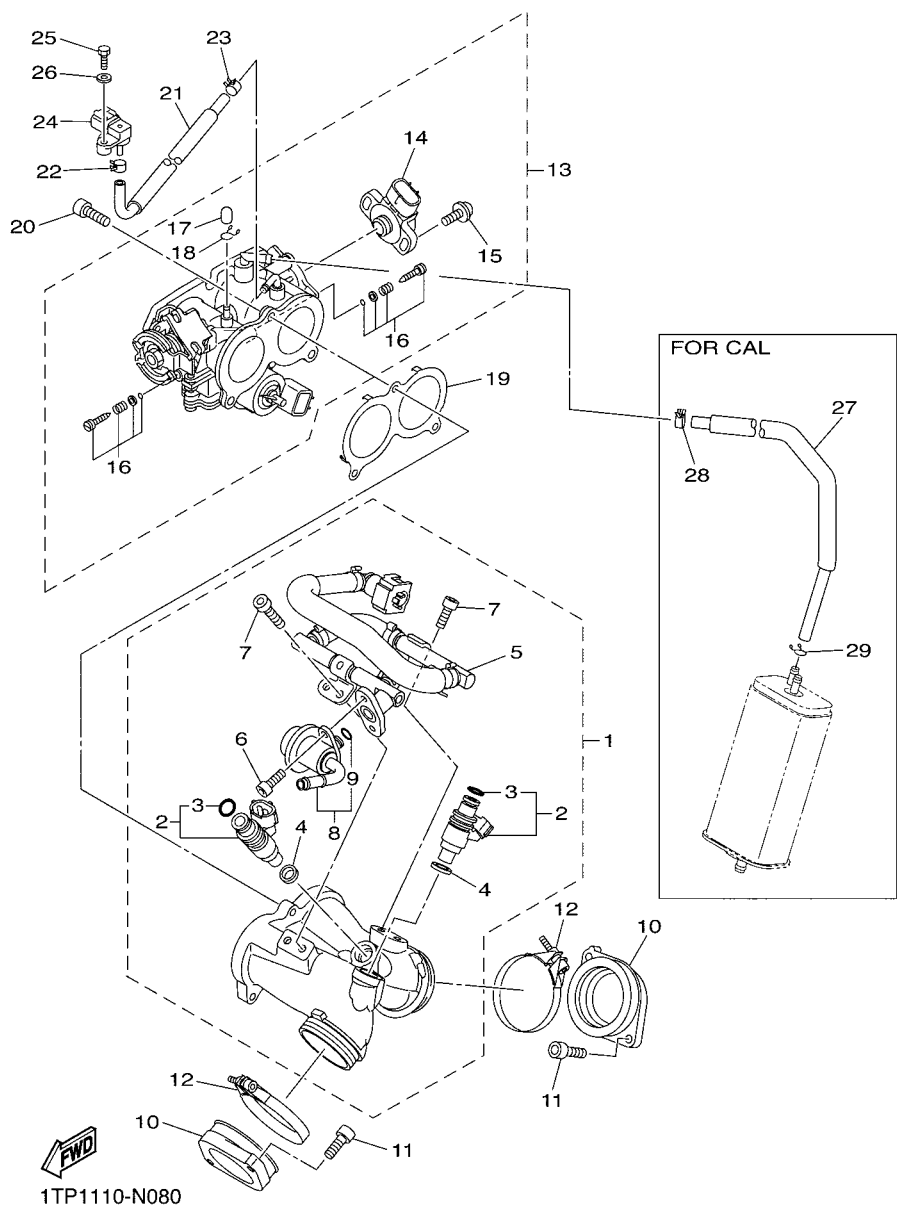

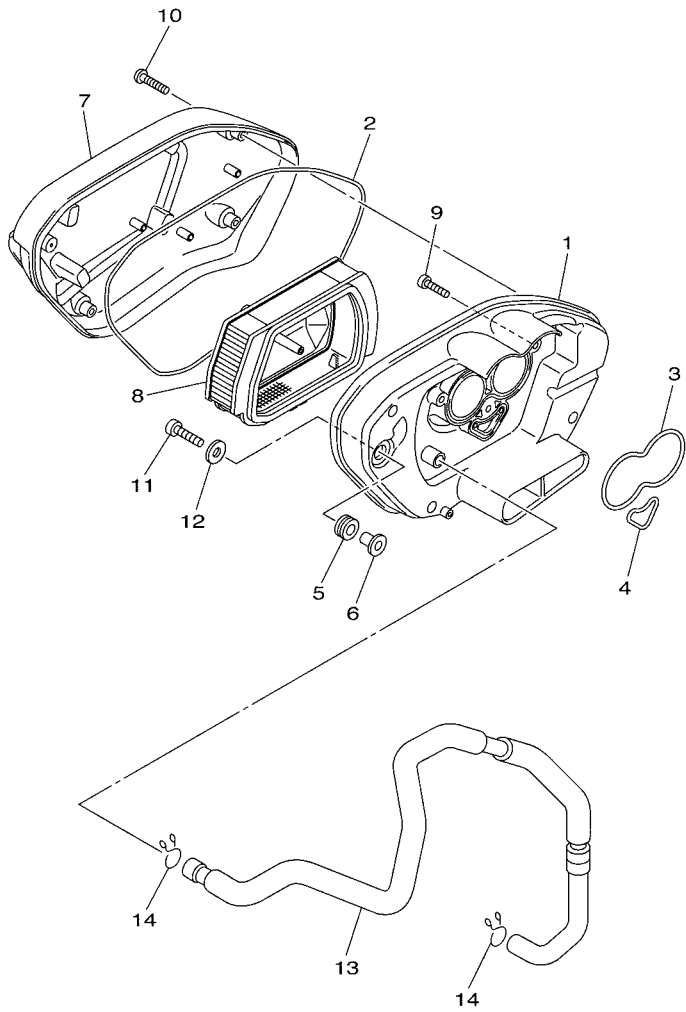

1TP1110-N090

FIG. 9 INTAKE 2

REF. NO.	PART NO.	DESCRIPTION	1TP1	1TP2	REMARKS
1	1TP-14411-00	CASE, AIR CLEANER 1	1	1	
2	1TP-14452-00	SEAL	1	1	
3	3D8-14457-00	SEAL	1	1	
4	3D8-14462-00	SEAL	1	1	
5	90480-14023	GROMMET	1	1	
6	90387-063E6	COLLAR	1	1	
7	1TP-14402-00	CAP ASSY, AIR CLEANER	1	1	
8	1TP-14451-00	ELEMENT, AIR CLEANER	1	1	
9	91312-05025	BOLT	3	3	
10	90111-05024	BOLT,HEX. SOCKET BUTTON	4	4	
11	91312-06025	BOLT	1	1	
12	90201-06062	WASHER, PLATE	1	1	
13	1TP-11166-00	PIPE, BREATHER 1	1	1	
14	90467-16195	CLIP	2	2	

FIG. 10 EXHAUST

REF. NO.	PART NO.	DESCRIPTION	TTP1	TTP2				REMARKS
1	1TP-14610-00	EXHAUST PIPE ASSY 1	1	1				
2	1TP-1465T-00	.PLATE, PROTECTOR 2	1	1				
3	1TP-1465U-00	.PLATE, PROTECTOR 3	1	1				
4	1TP-14629-00	.STAY, PROTECTOR	1	1				
5	90111-06148	.BOLT,HEX. SOCKET BUTTON	6	6				
6	90465-06017	.CLAMP	1	1				
7	1TP-14710-00	MUFFLER ASSY 1	1	1				
8	91314-08040	.BOLT, HEXAGON SOCKET HEAD	1	1				
9	5S7-14715-00	.BAND, MUFFLER	1	1				
10	5YU-14755-00	.GASKET, SILENCER	1	1				
11	1TP-14728-00	.PROTECTOR, MUFFLER 2	1	1				
12	1TP-14738-00	.PROTECTOR, MUFFLER 3	1	1				
13	1TP-14748-00	.PROTECTOR, MUFFLER 4	1	1				
14	1TP-14799-00	.CAP	1	1				
15	90111-06148	.BOLT,HEX. SOCKET BUTTON	12	12				
16	1TP-14772-00	.STAY, MUFFLER 2	1	1				
17	90111-10006	.BOLT,HEX. SOCKET BUTTON	2	2				
18	5D1-8592A-00	.SENSOR, OXYGEN	1	1				
19	3EG-14613-00	GASKET, EXHAUST PIPE	3	3				
20	1TP-14615-00	JOINT, EXHAUST 1	1	1				
21	90176-08012	NUT, CROWN	2	2				
22	1TP-1468W-00	PLATE, SILENCER 3	1	1				
23	95880-06010	BOLT, FLANGE	2	2				
24	90176-08006	NUT, CROWN	2	2				
25	90105-08251	BOLT, FLANGE	2	2				
26	90110-10042	BOLT, HEXAGON SOCKET HEAD	1	1				
27	90110-10038	BOLT, HEXAGON SOCKET HEAD	2	2				

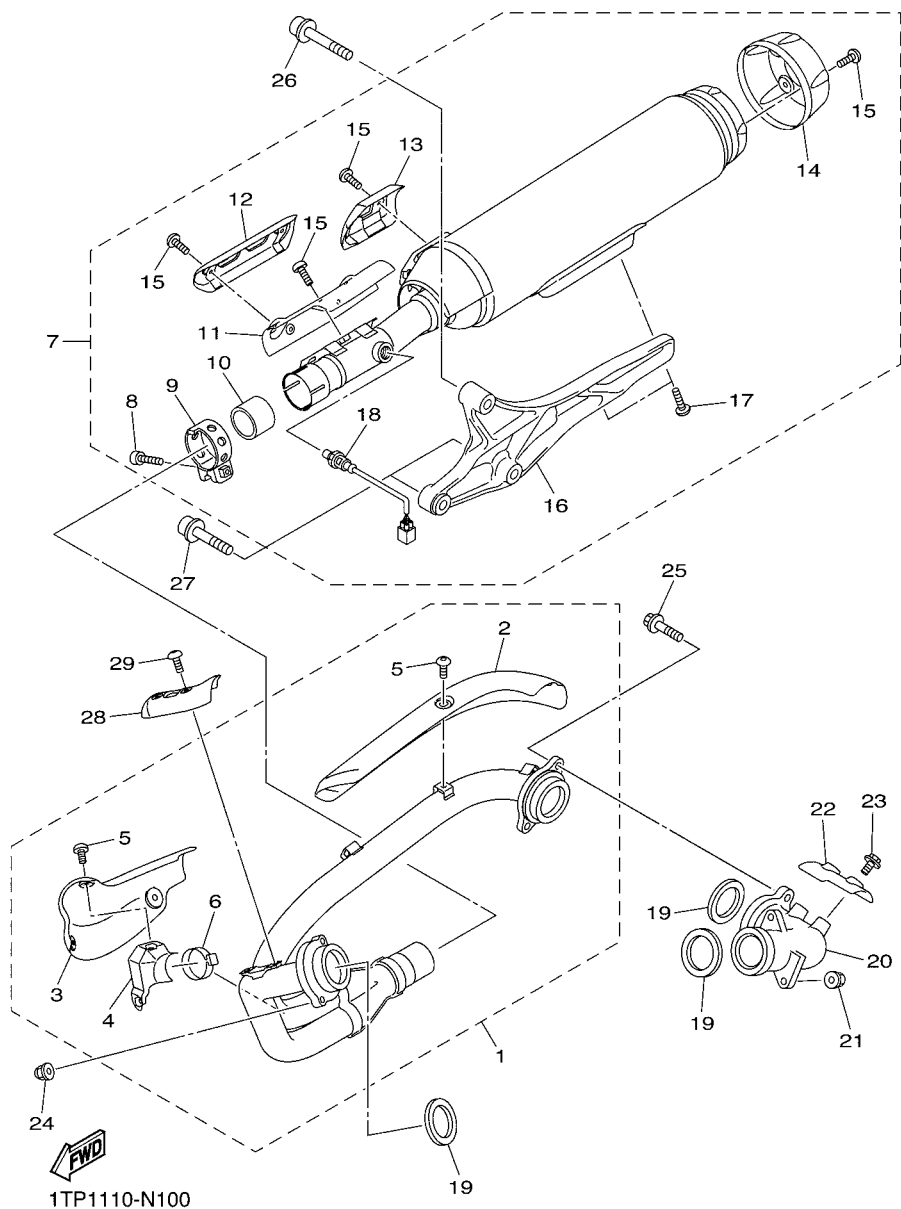

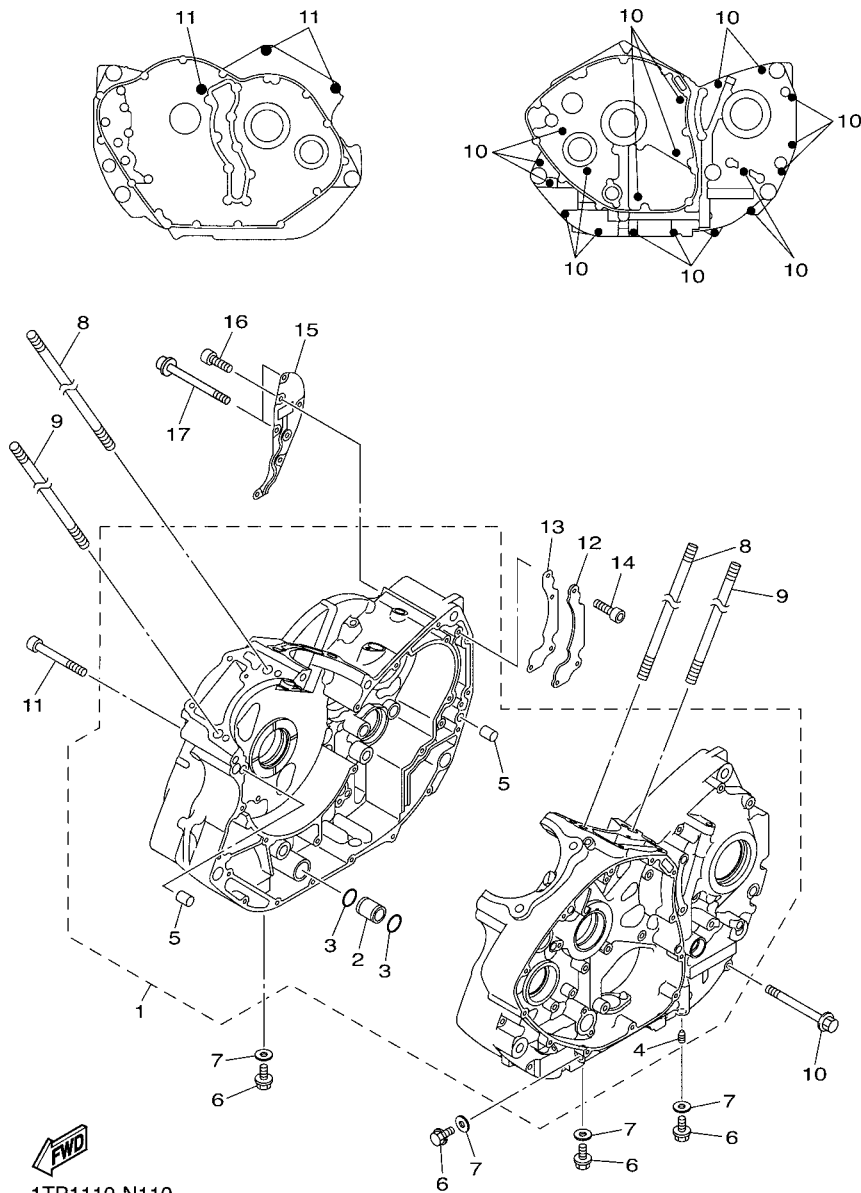

1TP1110-N110

FIG. 11 CRANKCASE

REF. NO.	PART NO.	DESCRIPTION	1TP1	1TP2	REMARKS
1	5S7-15100-09	CRANKCASE ASSY	1	1	
2	3D8-15154-00	.NOZZLE ASSY., 2	1	1	
3	93210-18319	.O-RING	2	2	
4	2H7-15138-00	.NOZZLE 1	1	1	
5	99530-10116	.PIN, DOWEL	2	2	
6	95022-10016	BOLT, FLANGE	4	4	
7	90430-10171	GASKET	4	4	
8	90116-12012	BOLT, STUD	6	6	
9	90116-12011	BOLT, STUD	2	2	
10	90105-06144	BOLT, FLANGE	19	19	
11	90110-10030	BOLT, HEXAGON SOCKET HEAD	3	3	
12	3D8-15358-00	SEPARATOR, OIL	1	1	
13	3D8-15353-00	GASKET, DRAIN	1	1	
14	90110-06161	BOLT, HEXAGON SOCKET HEAD	3	3	
15	3D8-15368-00	SEPARATOR, OIL	1	1	
16	90110-06161	BOLT, HEXAGON SOCKET HEAD	5	5	
17	90110-06270	BOLT, HEXAGON SOCKET HEAD	2	2	

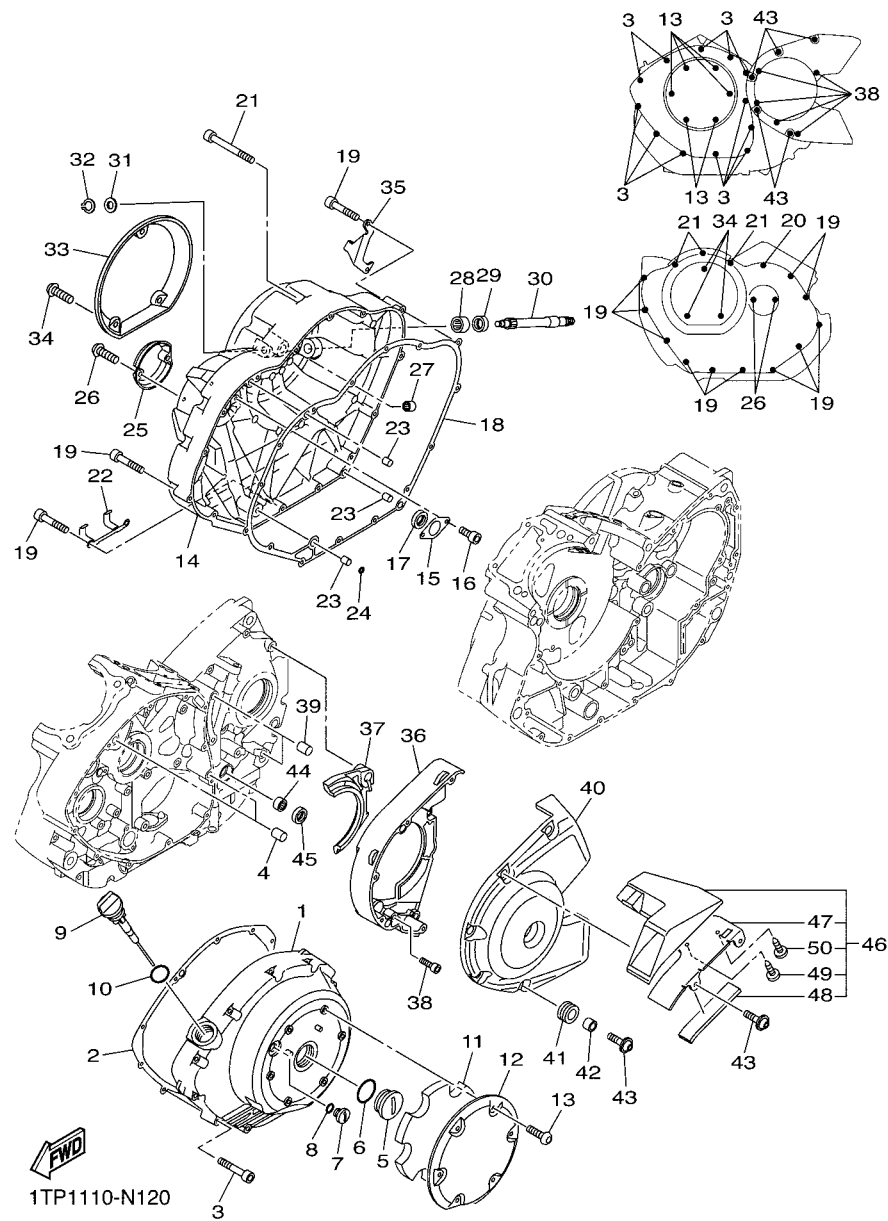

FIG. 12 CRANKCASE COVER 1

REF. NO.	PART NO.	DESCRIPTION	TTP1	TTP2	REMARKS
1	5S7-15411-00	COVER, CRANKCASE 1	1	1	
2	3D8-15451-00	GASKET, CRANKCASE COVER 1	1	1	
3	90110-06086	BOLT, HEXAGON SOCKET HEAD	12	12	
4	99530-08012	PIN, DOWEL	2	2	
5	90340-36078	PLUG, STRAIGHT SCREW	1	1	
6	93210-357A3	O-RING	1	1	
7	90340-14117	PLUG, STRAIGHT SCREW	1	1	
8	93210-14369	O-RING	1	1	
9	5S7-15362-10	PLUG, OIL LEVEL	1	1	
10	93210-27370	O-RING	1	1	
11	5S7-1542A-00	DAMPER 1	1	1	
12	1TP-15492-00	COVER	1	1	
13	92014-06014	BOLT, BUTTON HEAD	6	6	
14	5S7-15421-01	COVER, CRANKCASE 2	1	1	
15	3D8-15388-00	PLATE, BEARING COVER	1	1	
16	90110-06182	BOLT, HEXAGON SOCKET HEAD	2	2	
17	93101-14102	OIL SEAL	1	1	
18	3D8-15461-00	GASKET, CRANKCASE COVER 2	1	1	
19	90110-06086	BOLT, HEXAGON SOCKET HEAD	11	11	
20	90110-06311	BOLT, HEXAGON SOCKET HEAD	1	1	
21	90110-06334	BOLT, HEXAGON SOCKET HEAD	3	3	
22	1TP-81845-00	PLATE	1	1	
23	99530-08012	PIN, DOWEL	3	3	
24	93210-07135	O-RING	1	1	
25	1TP-15423-00	COVER 2	1	1	
26	92014-06014	BOLT, BUTTON HEAD	2	2	
27	93317-11096	BEARING	1	1	

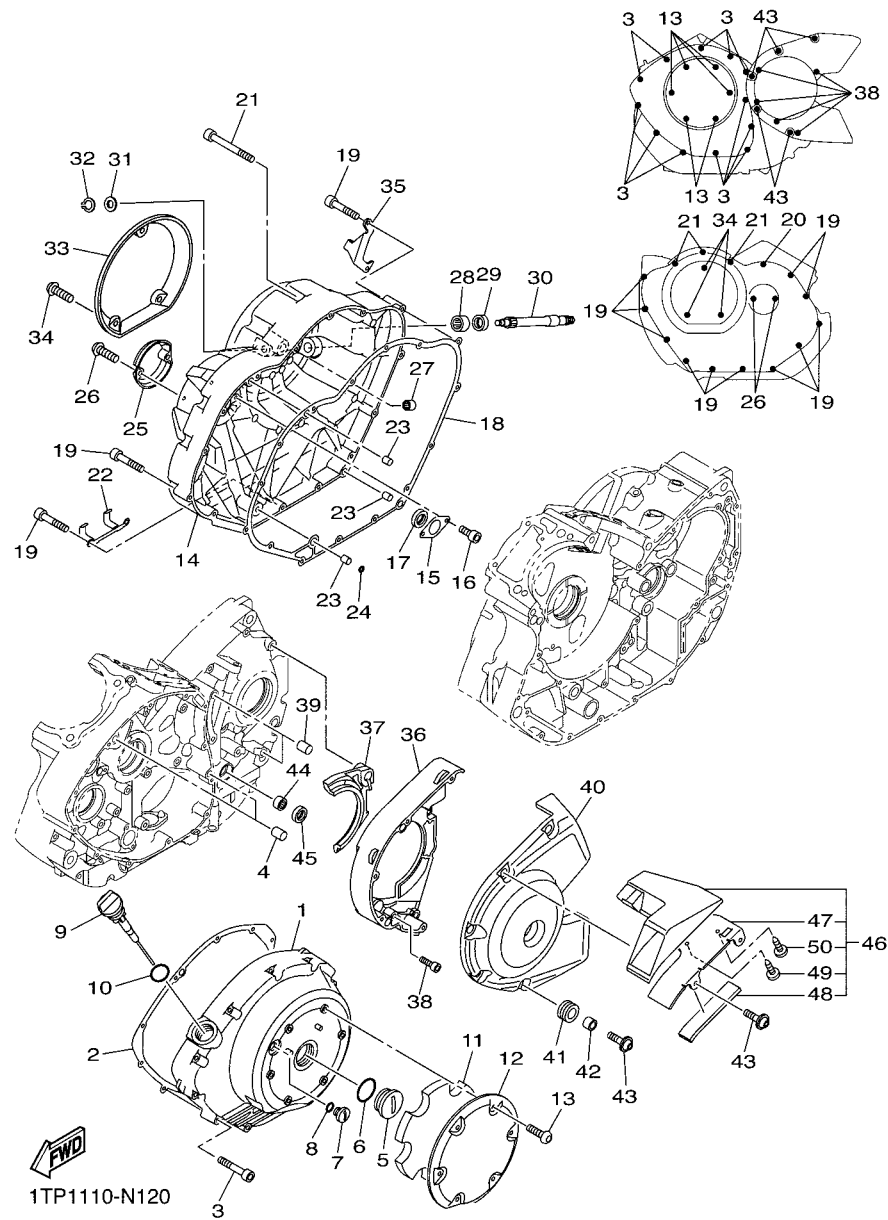
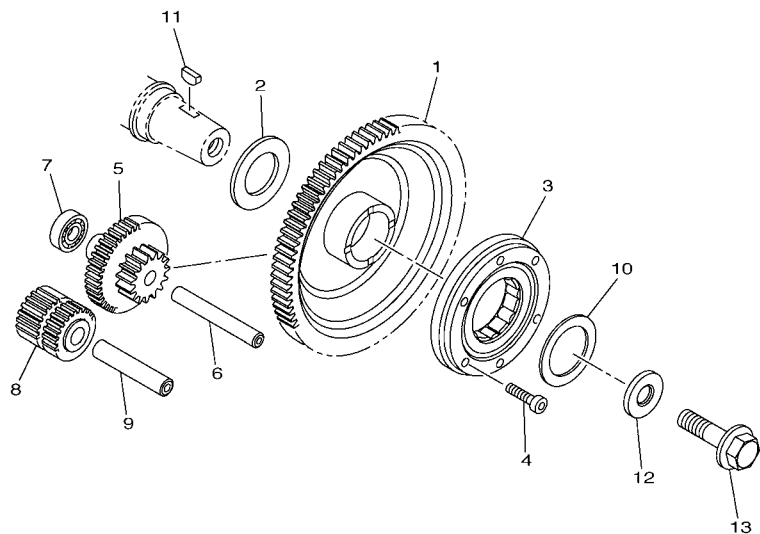

FIG. 12 CRANKCASE COVER 1

REF. NO.	PART NO.	DESCRIPTION	TTP1	TTP2	REMARKS
28	93315-31502	BEARING	1	1	
29	93102-15212	OIL SEAL	1	1	
30	3D8-16382-00	AXLE, PUSH LEVER	1	1	
31	92902-08600	WASHER, PLATE	1	1	
32	99002-07600	CLIP	1	1	
33	1TP-15415-00	COVER, GENERATOR	1	1	
34	92014-06014	BOLT, BUTTON HEAD	3	3	
35	3D8-15441-00	HOLDER, CLUTCH CABLE	1	1	
36	3D8-1541A-01	STAY, CRANKCASE COVER 1	1	1	
37	3D8-15337-02	DAMPER 4	1	1	
38	91312-08035	BOLT	5	5	
39	99590-10114	PIN, DOWEL	2	2	
40	1TP-15426-00	COVER, OIL PUMP 2	1	1	
41	90480-13018	GROMMET	5	5	
42	90387-06286	COLLAR	5	5	
43	90111-06130	BOLT, HEX. SOCKET BUTTON	5	5	
44	93317-11287	BEARING	1	1	
45	93102-12106	OIL SEAL (SD 12-22-5 HS)	1	1	
46	1TP-15470-00	AIR DUCT ASSY	1	1	
47	1TP-15113-00	.PLATE	1	1	
48	5S7-15316-00	.DAMPER 1	1	1	
49	97702-40014	.SCREW, TAPPING	2	2	
50	97702-40010	.SCREW, TAPPING	1	1	

FIG. 13 STARTER



REF. NO.	PART NO.	DESCRIPTION	TTP1	TTP2				REMARKS
1	5S7-15515-00	GEAR 3	1	1				
2	5S7-15561-00	WASHER	1	1				
3	4NK-15590-00	STARTER ONE-WAY ASSY	1	1				
4	90110-08067	BOLT, HEXAGON SOCKET HEAD	3	3				
5	5S7-15512-01	GEAR, IDLER 1	1	1				
6	1D7-15521-00	SHAFT 1	1	1				
7	93306-00006	BEARING	1	1				
8	3D8-15512-01	GEAR, IDLER 1	1	1				
9	4WM-15522-00	SHAFT 2	1	1				
10	90201-350F3	WASHER, PLATE	1	1				
11	90280-05048	KEY, WOODRUFF	1	1				
12	90201-12008	WASHER, PLATE	1	1				
13	90105-12584	BOLT, FLANGE	1	1				



5S71110-H130

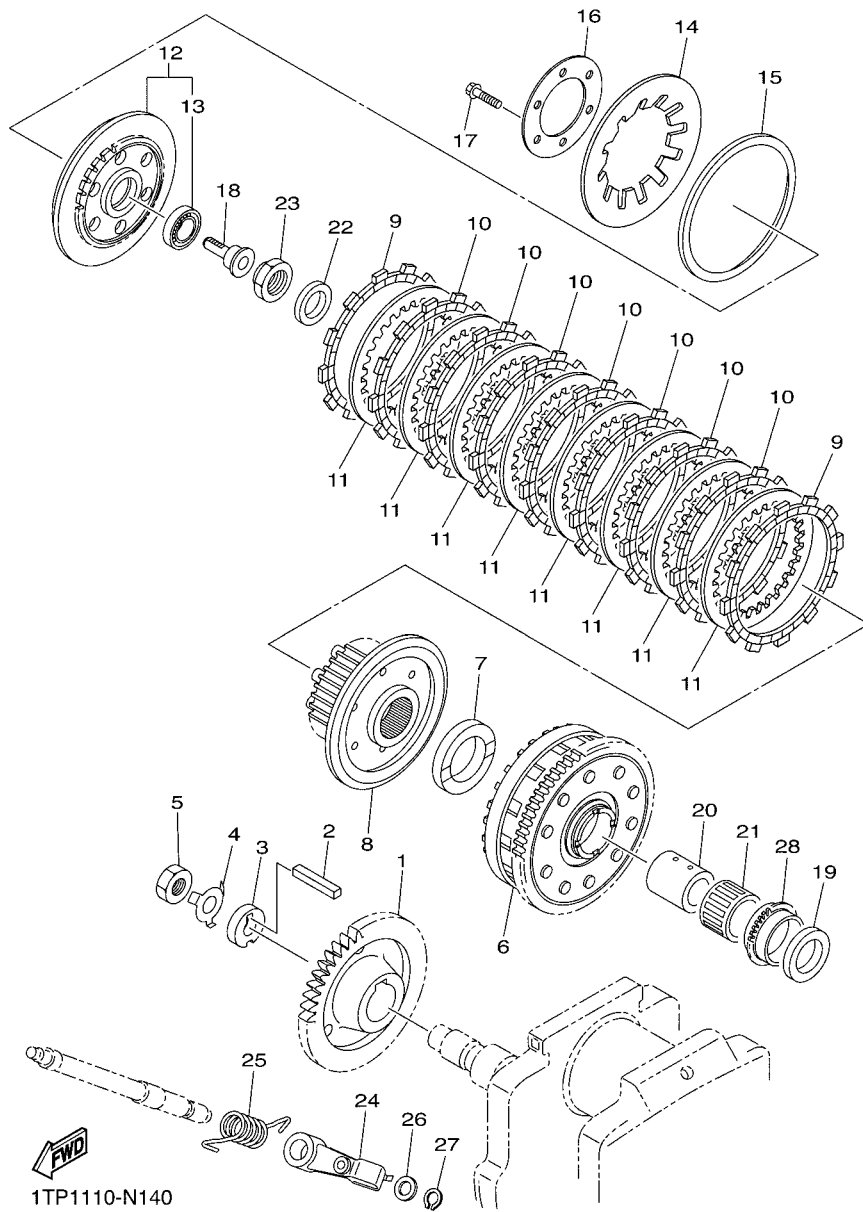
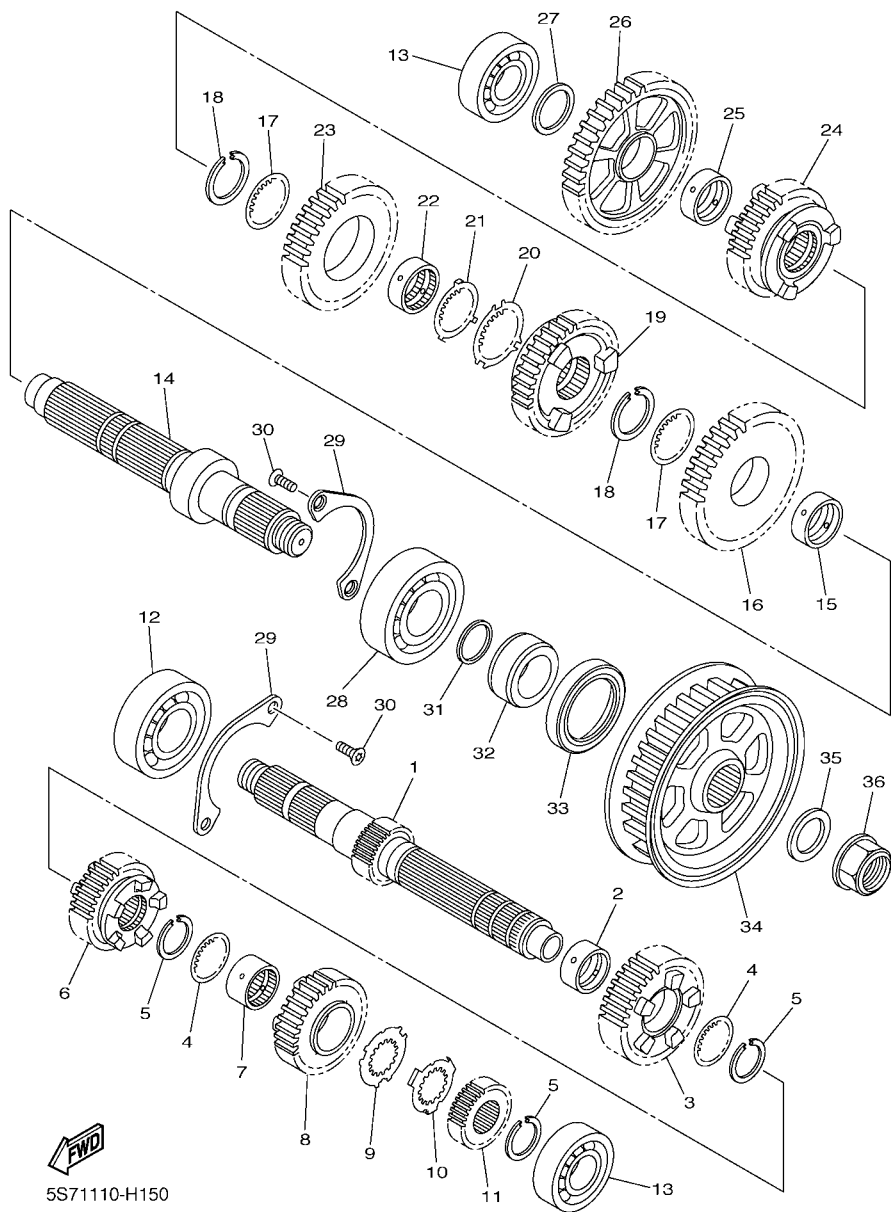

FIG. 14 CLUTCH

REF. NO.	PART NO.	DESCRIPTION	TTP1	TTP2	REMARKS
1	5S7-16111-00	GEAR, PRIMARY DRIVE	1	1	
2	4WM-16193-00	KEY, FEATHER	1	1	
3	3D8-16181-10	SPACER 1	1	1	
4	90215-18003	WASHER, LOCK	1	1	
5	90170-18008	NUT	1	1	
6	1TP-16150-00	PRIMARY DRIVEN GEAR COMP.	1	1	
7	5YU-16154-00	PLATE, THRUST 1	1	1	
8	3D8-16371-00	BOSS, CLUTCH	1	1	
9	341-16321-20	PLATE, FRICTION	2	2	
10	5JW-16321-10	PLATE, FRICTION	7	7	
11	2H7-16325-00	PLATE, CLUTCH 2	8	8	
12	3D8-16350-00	PRESSURE PLATE ASSY	1	1	
13	93306-00304	.BEARING	1	1	
14	5S7-16334-00	SPRING, CLUTCH 2	1	1	
15	36Y-16335-00	HOUSING, SPRING	1	1	
16	1TX-16352-00	PLATE, PRESSURE 2	1	1	
17	97002-06025	BOLT	6	6	
18	4XV-16356-01	ROD, PUSH 1	1	1	
19	3D8-16164-10	PLATE, THRUST 2	1	1	
20	90387-26006	COLLAR	1	1	
21	93310-33560	BEARING	1	1	
22	90208-20001	WASHER, CONICAL SPRING	1	1	
23	90179-20007	NUT	1	1	
24	5S7-16340-00	PUSH LEVER ASSY	1	1	
25	90508-18040	SPRING, TORSION	1	1	
26	90201-10029	WASHER, PLATE	1	1	
27	99009-10400	CIRCLIP	1	1	

FIG. 15 TRANSMISSION

REF. NO.	PART NO.	DESCRIPTION	TTP1	TTP2	REMARKS
1	5S7-17411-10	AXLE, MAIN (15T)	1	1	
2	90387-28003	COLLAR	1	1	
3	5S7-17151-00	GEAR, 5TH PINION (24T)	1	1	
4	90209-25011	WASHER	2	2	
5	93440-28184	CIRCLIP	3	3	
6	5S7-17131-10	GEAR, 3RD PINION (19T)	1	1	
7	90387-25025	COLLAR	1	1	
8	5S7-17141-10	GEAR, 4TH PINION (27T)	1	1	
9	90214-25004	WASHER, CLAW	1	1	
10	90214-25003	WASHER, CLAW	1	1	
11	5S7-17121-00	GEAR, 2ND PINION (16T)	1	1	
12	93306-37817	BEARING	1	1	
13	93306-37215	BEARING	2	2	
14	5S7-17421-00	AXLE, DRIVE	1	1	
15	90387-31003	COLLAR	1	1	
16	5S7-17221-00	GEAR, 2ND WHEEL (33T)	1	1	
17	90209-28008	WASHER	2	2	
18	93440-31187	CIRCLIP	2	2	
19	5S7-17241-10	GEAR, 4TH WHEEL (34T)	1	1	
20	90214-29002	WASHER, CLAW	1	1	
21	90214-28002	WASHER, CLAW	1	1	
22	90387-28004	COLLAR	1	1	
23	5S7-17231-00	GEAR, 3RD WHEEL (30T)	1	1	
24	5S7-17251-00	GEAR, 5TH WHEEL (25T)	1	1	
25	90387-25008	COLLAR	1	1	
26	5S7-17211-00	GEAR, 1ST WHEEL (46T)	1	1	
27	90201-224L4	WASHER, PLATE	1	1	



5S71110-H150

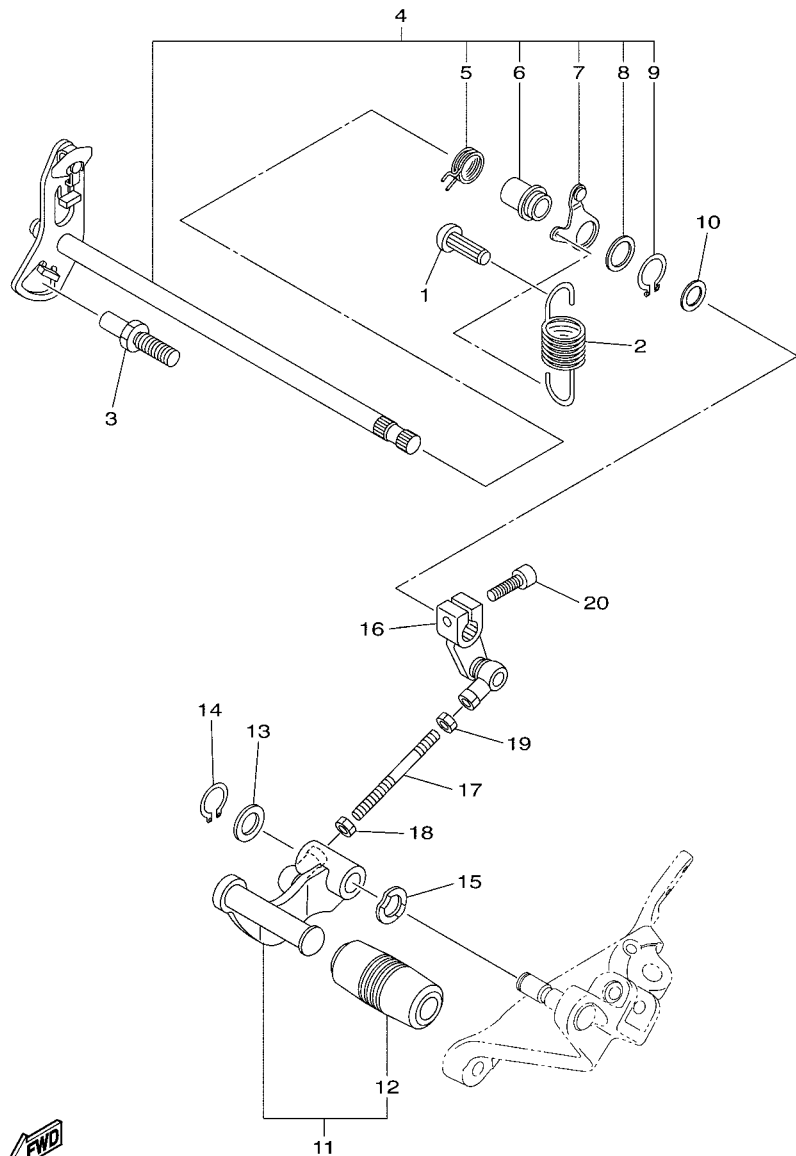

1TP1110-N170

FIG. 17 SHIFT SHAFT

REF. NO.	PART NO.	DESCRIPTION	1TP1	1TP2	REMARKS
1	132-16346-00	HOOK, SPRING	1	1	
2	90506-18015	SPRING, TENSION	1	1	
3	1D7-18127-00	STOPPER, SCREW	1	1	
4	3D8-18101-00	SHIFT SHAFT ASSY	1	1	
5	90508-32040	.SPRING, TORSION	1	1	
6	3D8-18175-00	.SPACER	1	1	
7	3D8-18140-00	.STOPPER LEVER ASSY	1	1	
8	90201-177G4	.WASHER, PLATE	1	1	
9	99009-17400	.CIRCLIP	1	1	
10	90201-127E1	WASHER, PLATE	1	1	
11	1TP-18110-00	SHIFT PEDAL ASSY	1	1	
12	5VN-18113-00	.COVER, SHIFT PEDAL	1	1	
13	90201-12688	WASHER, PLATE	1	1	
14	99009-12400	CIRCLIP	1	1	
15	90206-12074	WASHER, WAVE	1	1	
16	1TP-18112-00	ARM, SHIFT	1	1	
17	1TP-18115-00	ROD, SHIFT	1	1	
18	90170-06024	NUT	1	1	
19	95314-06600	NUT	1	1	
20	91312-06020	BOLT	1	1	

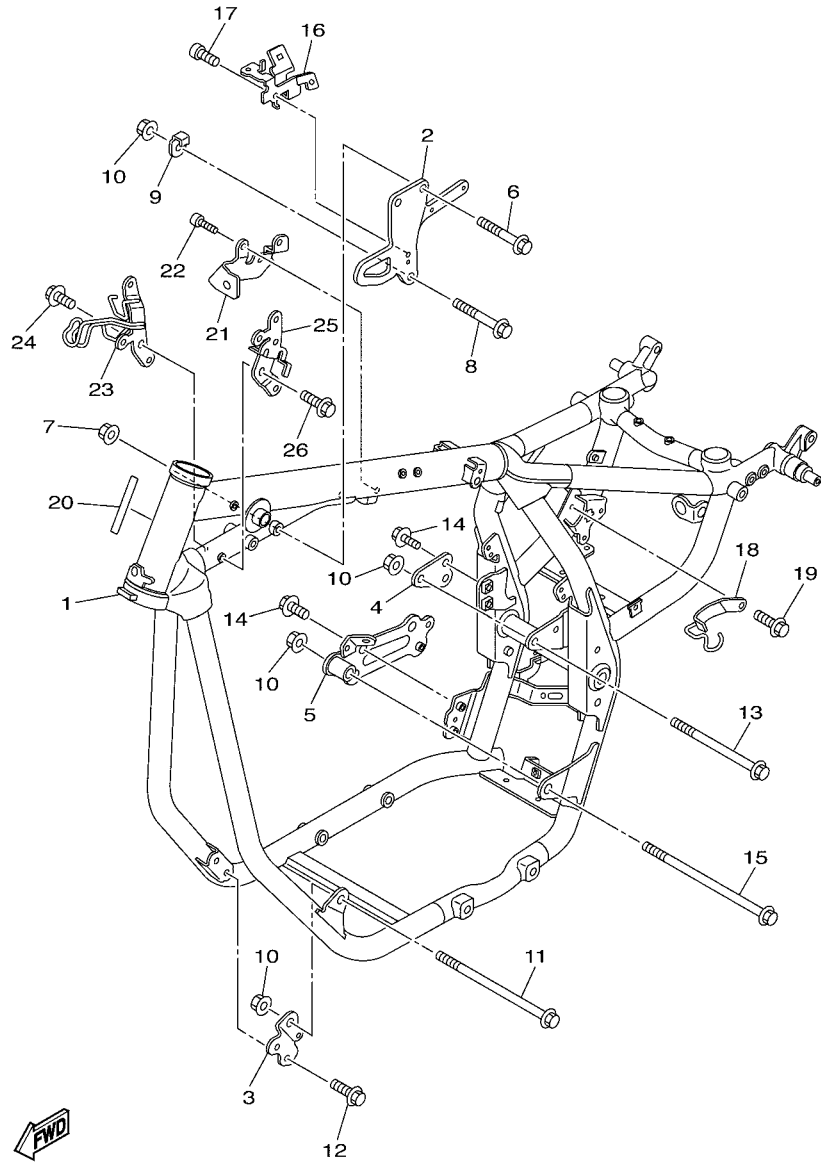

1TP1110-N180

FIG. 18 FRAME

REF. NO.	PART NO.	DESCRIPTION	TTP1	TTP2	REMARKS
1	1TP-21110-00	FRAME COMP.	1	1	
2	1TP-21317-00	STAY, ENGINE 3	1	1	
3	1TP-2122C-00	STAY 3	1	1	
4	1TP-21314-00	STAY, ENGINE 5	1	1	
5	1TP-2116F-00	STAY, REAR	1	1	
6	90105-10434	BOLT, FLANGE	2	2	
7	90185-10008	NUT, SELF-LOCKING	2	2	
8	90105-12090	BOLT, FLANGE	1	1	
9	1TP-21183-00	PLATE	1	1	
10	90185-12002	NUT, SELF-LOCKING	4	4	
11	90105-12088	BOLT, FLANGE	1	1	
12	90105-10415	BOLT, FLANGE	2	2	
13	90105-12091	BOLT, FLANGE	1	1	
14	90105-10428	BOLT, FLANGE	4	4	
15	90105-12086	BOLT, FLANGE	1	1	
16	1TP-2115C-00	BRKT	1	1	
17	91317-06008	BOLT	1	1	
18	1TP-21288-00	GUIDE, CABLE	1	1	
19	95027-06010	BOLT, FLANGE	1	1	
20	3D8-2117G-00	PROTECTOR	1	1	
21	1TP-21149-00	BRACKET, BATTERY BOX	1	1	
22	90111-06085	BOLT, HEX. SOCKET BUTTON	2	2	
23	1TP-26475-00	HOLDER	1	1	
24	95027-06016	BOLT, FLANGE	2	2	
25	1TP-26481-00	HOLDER, 2	1	1	
26	95027-06016	BOLT, FLANGE	2	2	

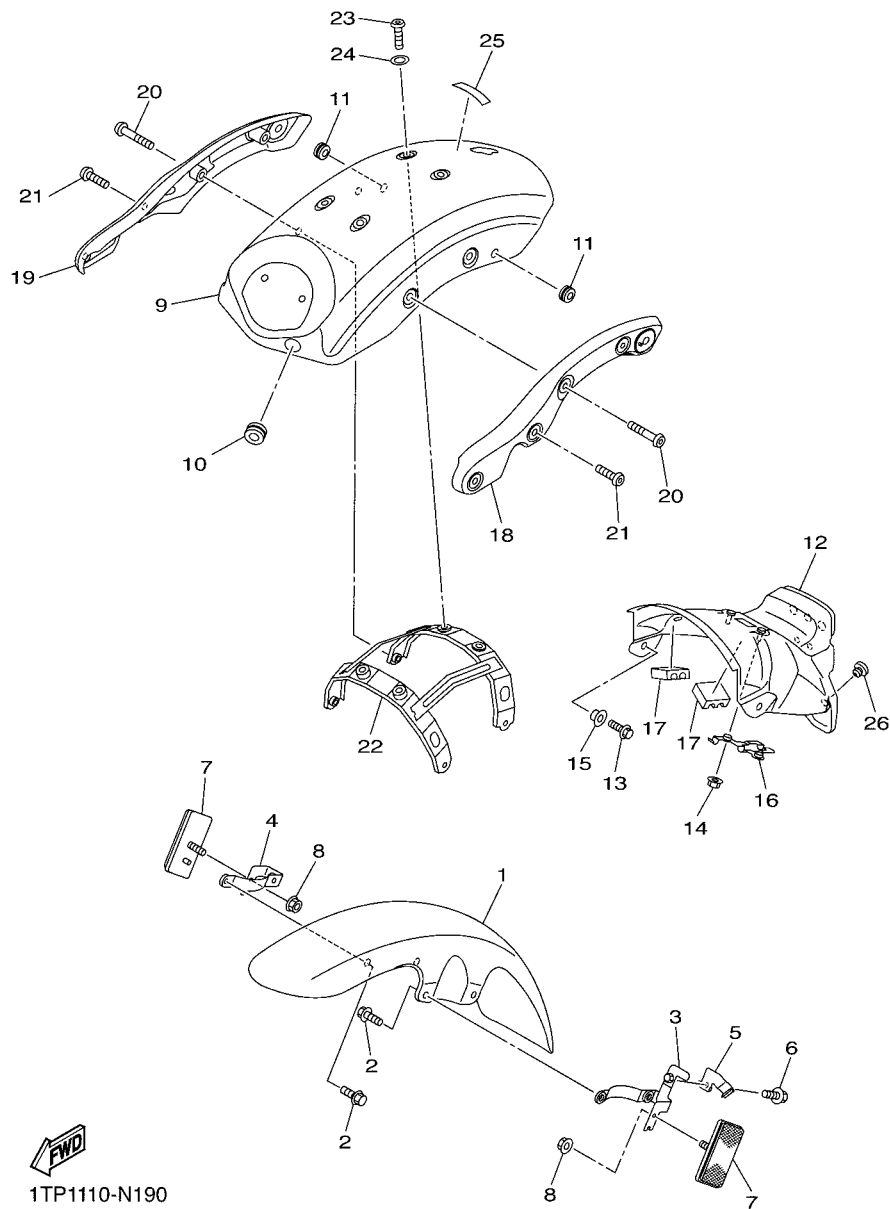
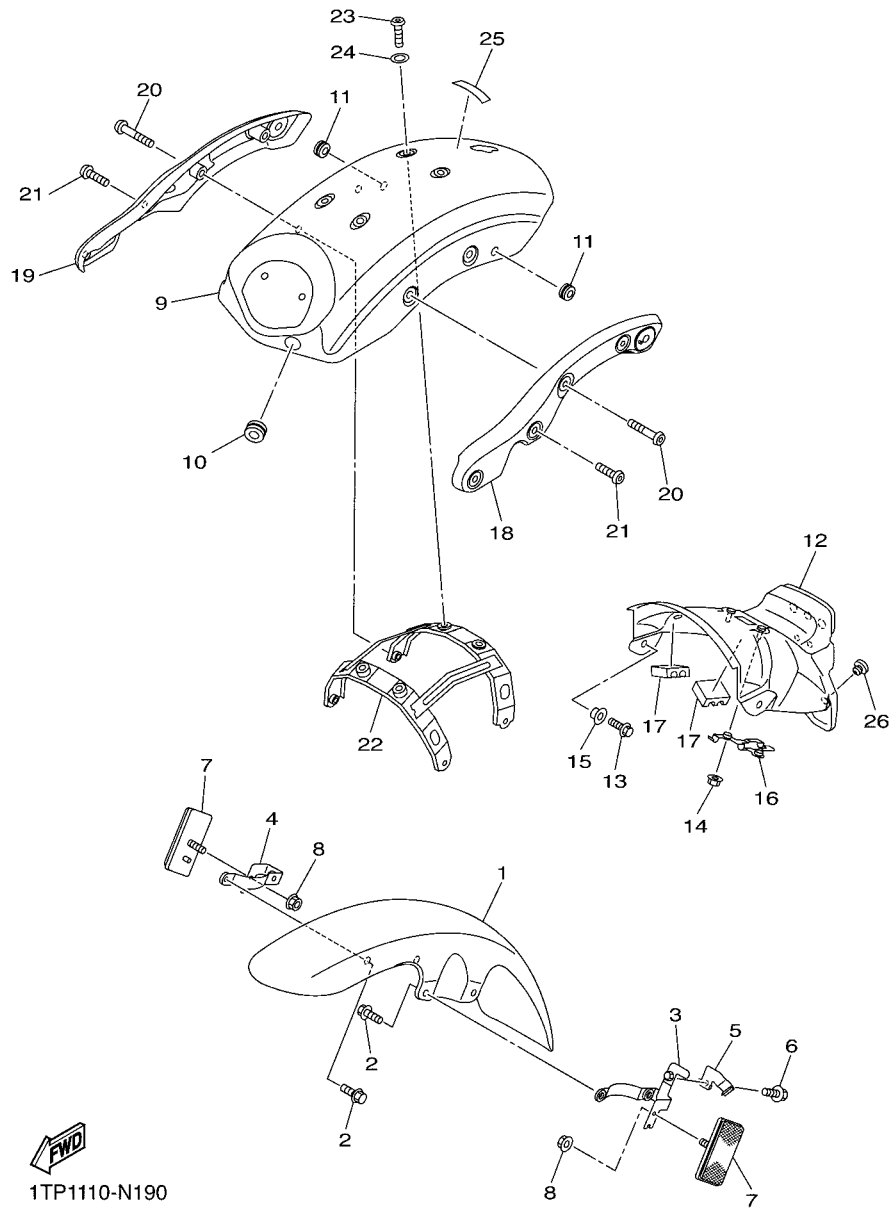

FIG. 19 FENDER

REF. NO.	PART NO.	DESCRIPTION	1TP1	1TP2	REMARKS
1	1TP-21510-00-P0	FRONT FENDER COMP.	1	1	UR FOR SMX
	1TP-21510-00-P1	FRONT FENDER COMP.	1	1	UR FOR BWC1
2	95812-08020	BOLT, FLANGE	4	4	
3	1TP-21587-00	STAY 1	1	1	
4	1TP-21588-00	STAY 2	1	1	
5	27D-25887-00	HOLDER, BRAKE HOSE	1	1	
6	95027-06010	BOLT, FLANGE	1	1	
7	11H-85110-01	REFLECTOR ASSY	2	2	
8	95707-05500	NUT, FLANGE	2	2	
9	1TP-21610-00-P0	REAR FENDER COMP.	1	1	UR FOR SMX
	1TP-21610-00-P1	REAR FENDER COMP.	1	1	UR FOR BWC1
10	90480-01015	GROMMET	1	1	
11	90480-13016	GROMMET	2	2	
12	1TP-2162R-00	FENDER 2	1	1	
13	95822-06014	BOLT, FLANGE	2	2	
14	95602-06200	NUT, SELF-LOCKING	2	2	
15	90387-07717	COLLAR	2	2	
16	1TP-21688-00	BRACKET, REAR STAY	1	1	
17	1TP-21639-00	DAMPER 2	2	2	
18	1TP-21613-00	STAY, FENDER 1	1	1	
19	1TP-21614-00	STAY, FENDER 2	1	1	
20	90111-08005	BOLT,HEX. SOCKET BUTTON	4	4	
21	90111-10006	BOLT,HEX. SOCKET BUTTON	4	4	
22	1TP-21643-00	STAY, REAR	1	1	
23	90111-08081	BOLT,HEX. SOCKET BUTTON	4	4	
24	90201-08066	WASHER, PLATE	4	4	
25	1D6-2153E-00	EMBLEM, YAMAHA	1	1	



1TP1110-N190

FIG. 19 FENDER

REF. NO.	PART NO.	DESCRIPTION	1TP1	1TP2		REMARKS
26	90338-07010	PLUG	1	1		

FIG. 20 SIDE COVER

REF. NO.	PART NO.	DESCRIPTION	1TP1	1TP2			REMARKS
1	1TP-2177G-00	BOX, BATTERY	1	1			
2	90480-07003	GROMMET	2	2			
3	90387-06239	COLLAR	2	2			
4	90183-060A6	NUT, SPRING	2	2			
5	1TP-2172E-00	STAY, SIDE COVER 1	1	1			
6	92017-06012	BOLT, BUTTON HEAD	2	2			
7	5S7-2139X-00	DAMPER	2	2			
8	90387-06267	COLLAR	1	1			
9	95022-06014	BOLT, FLANGE	6	6			
10	90201-062P7	WASHER, PLATE	2	2			
11	1TP-2177A-00	BOX	1	1			
12	3TJ-82131-00	BAND, BATTERY	1	1			
13	1TP-82131-00	BAND, BATTERY	1	1			
14	18G-82131-00	BAND, BATTERY	1	1			
15	90269-07077	RIVET	1	1			
16	1TP-28170-00	HOLDER, TOOL	1	1			
17	18G-82131-00	BAND, BATTERY	1	1			
18	90480-20001	GROMMET	1	1			
19	1TP-21711-00	COVER, SIDE 1	1	1			
20	55K-21708-00	LOCK ASSY 2	1	1			
21	90170-22187	NUT	1	1			
22	90480-24186	GROMMET	1	1			
23	90480-13398	GROMMET	1	1			
24	2N4-21717-00	DAMPER	1	1			
25	1TP-21721-00	COVER, SIDE 2	1	1			
26	90387-06173	COLLAR	1	1			
27	90183-060A6	NUT, SPRING	1	1			

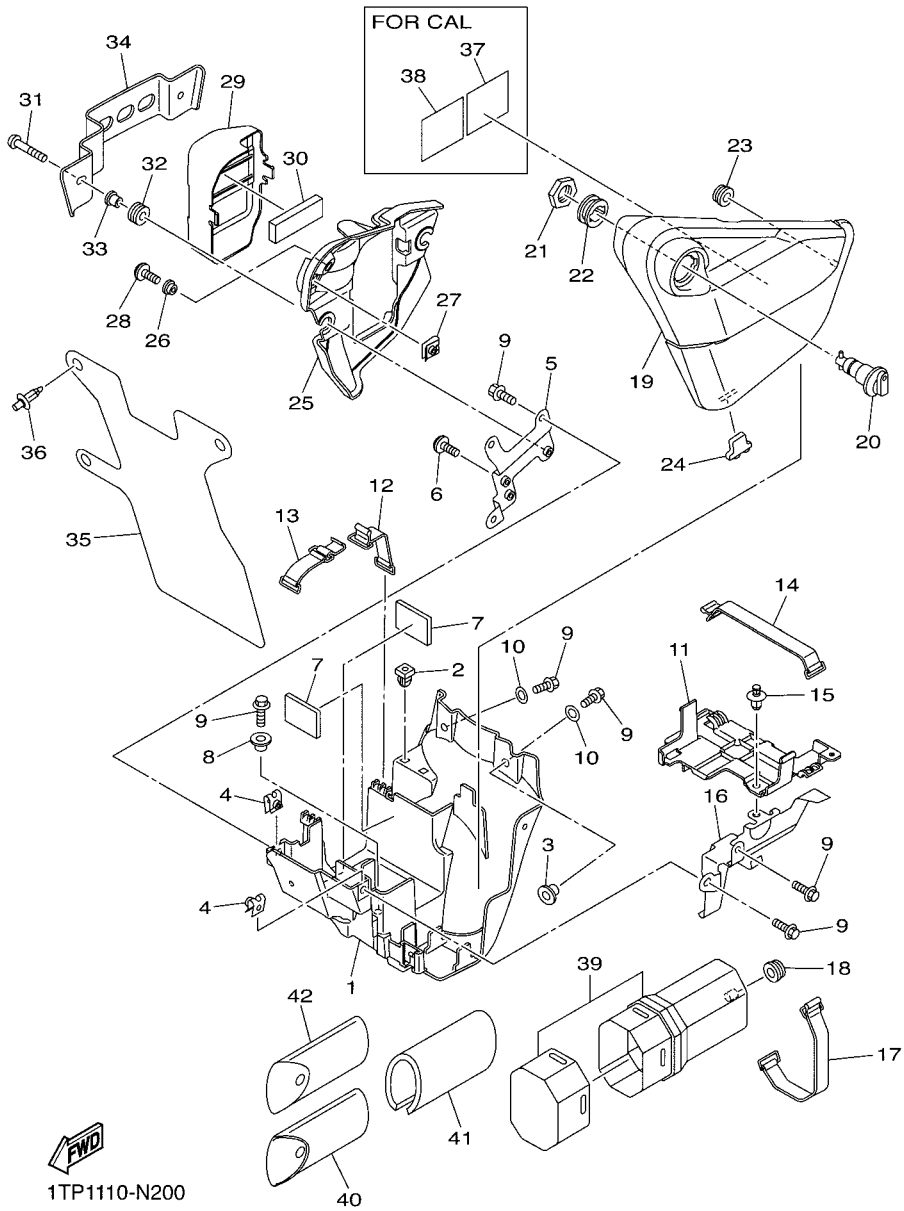
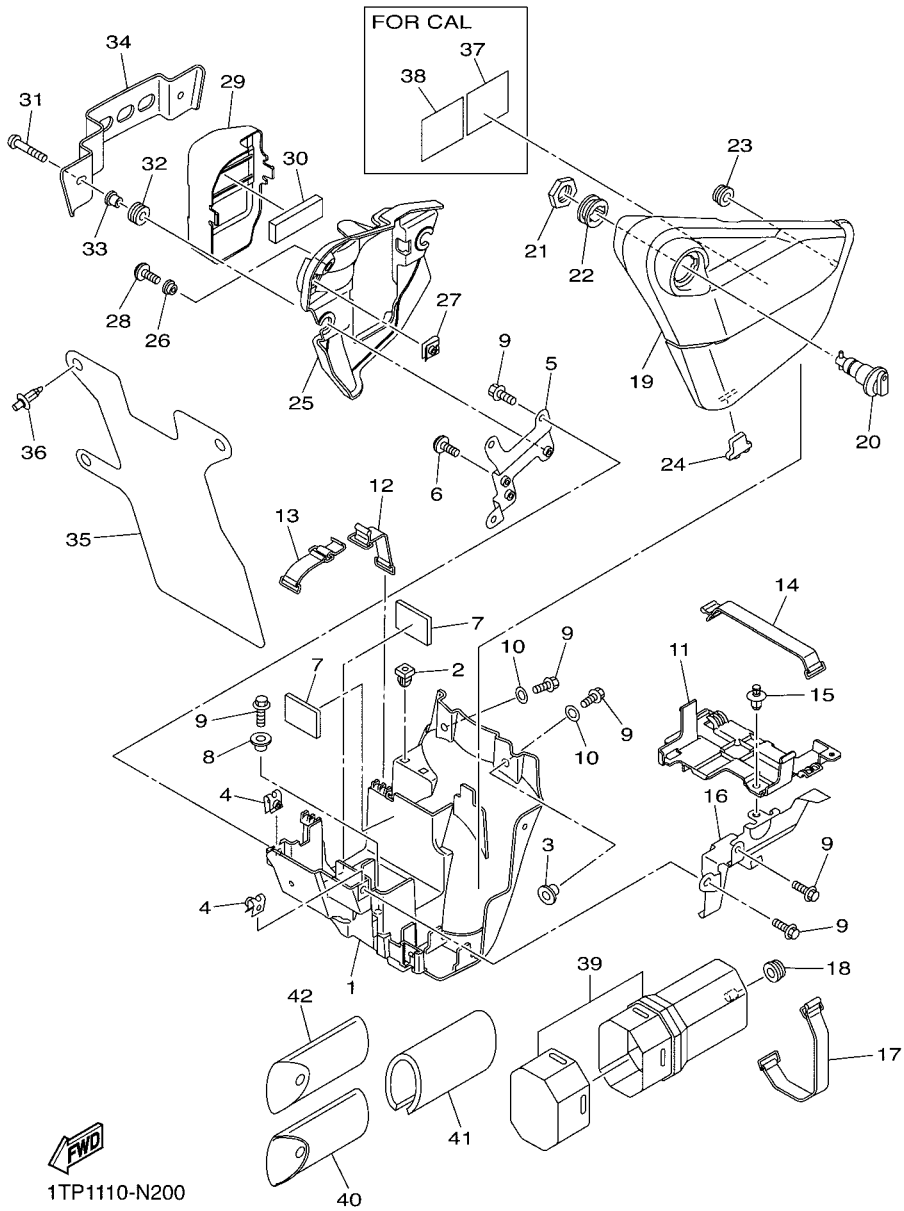
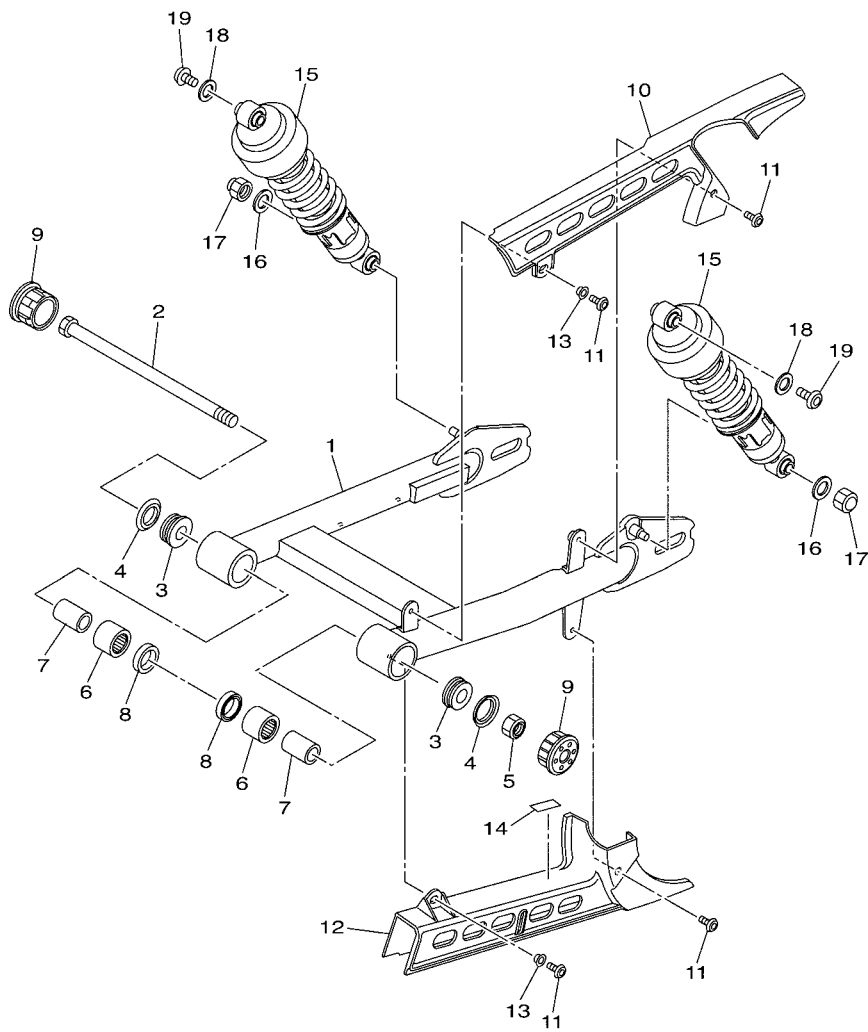

FIG. 20 SIDE COVER

REF. NO.	PART NO.	DESCRIPTION	TTP1	TTP2	REMARKS
28	90111-06038	BOLT,HEX. SOCKET BUTTON	1	1	
29	1TP-2124E-00	COVER, BATTERY	1	1	
30	4D3-24181-00	DAMPER, LOCATING 1	1	1	
31	90111-06030	BOLT,HEX. SOCKET BUTTON	2	2	
32	90480-14003	GROMMET	2	2	
33	90387-0602X	COLLAR	2	2	
34	1TP-2176E-00	PLATE	1	1	
35	1TP-2172W-00	COVER	1	1	
36	90269-06008	RIVET	3	3	
37	5RU-21686-00	PLATE, ROUTING 2	1		FOR CALIFORNIA
38	34B-21684-00	PLATE, ROUTING	1		FOR CALIFORNIA
39	1TP-28173-00	BOX, TOOL	1	1	
40	3D8-28100-10	TOOL KIT	1	1	
41	90520-08003	DAMPER, PLATE	1	1	
42	1TP-28110-00	TOOL KIT, 2	1	1	





1TP1110-N210

FIG. 21 REAR ARM & SUSPENSION

REF. NO.	PART NO.	DESCRIPTION	1TP1	1TP2			REMARKS
1	1TP-22110-00	REAR ARM COMP.	1	1			
2	1TP-22141-00	SHAFT, PIVOT	1	1			
3	90387-16030	COLLAR	2	2			
4	93108-44001	OIL SEAL	2	2			
5	95602-16100	NUT, U	1	1			
6	93317-52897	BEARING	2	2			
7	90387-16032	COLLAR	2	2			
8	93109-28001	OIL SEAL	2	2			
9	1TP-2219X-00	COVER	2	2			
10	1TP-22311-00	CASE, CHAIN	1	1			
11	90111-06127	BOLT, HEX. SOCKET BUTTON	4	4			
12	1TP-22312-00	CASE, CHAIN 2	1	1			
13	90387-06048	COLLAR	2	2			
14	1TP-21668-00	LABEL, TIRE	1	1			
15	1TP-22210-00	SHOCK ABSORBER ASSY, REAR	2	2			
16	90201-10074	WASHER, PLATE	2	2			
17	90176-10073	NUT, CROWN	2	2			
18	90201-08119	WASHER, PLATE	2	2			
19	90149-08054	SCREW	2	2			

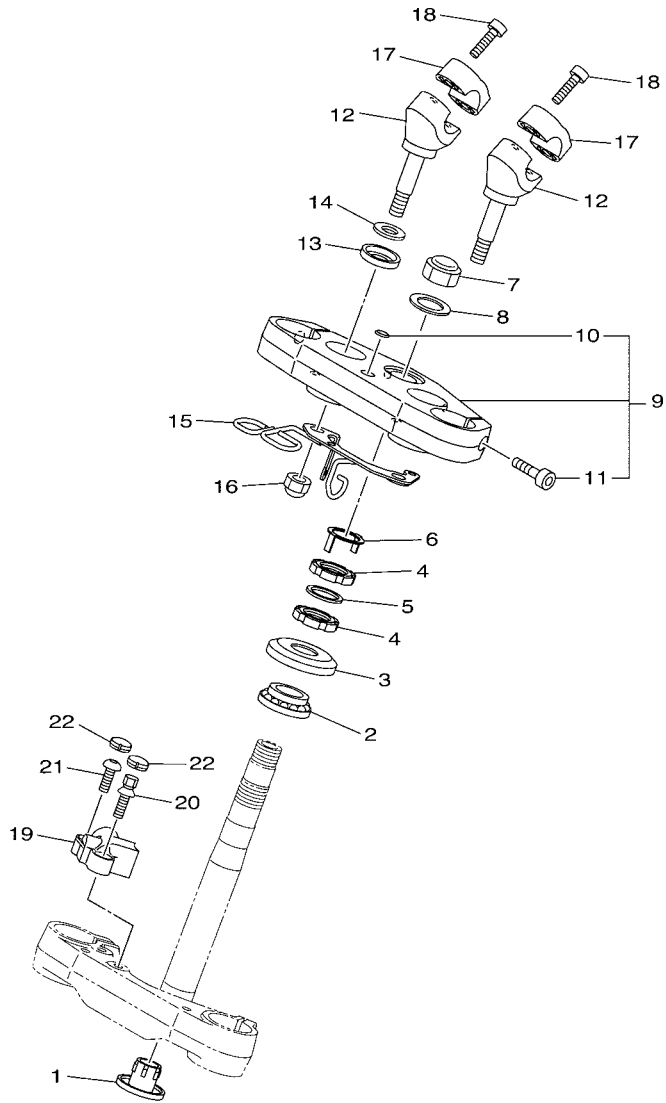

1TP1110-N220

FIG. 22 STEERING

REF. NO.	PART NO.	DESCRIPTION	TTP1	TTP2	REMARKS
1	4KM-23123-01	COVER, UNDER 1	1	1	
2	93399-99931	BEARING	1	1	
3	1W1-23416-00	COVER, BALL RACE 2	1	1	
4	90179-25004	NUT	2	2	
5	90202-26142	WASHER, PLATE	1	1	
6	26H-23418-01	WASHER, SPECIAL	1	1	
7	90176-22002	NUT, CROWN	1	1	
8	90201-220T0	WASHER, PLATE	1	1	
9	1TP-Y2343-00	CROWN, HANDLE	1	1	
10	14B-2836B-00	.TUNING FORK MARK	1	1	
11	91314-08030	.BOLT, HEXAGON SOCKET HEAD	2	2	
12	1TP-23442-00	HOLDER, HANDLE LOWER	2	2	
13	3DM-23445-00	DAMPER	2	2	
14	90201-14220	WASHER, PLATE	2	2	
15	1TP-23389-00	GUIDE, CABLE	1	1	
16	90176-12052	NUT, CROWN	2	2	
17	1TP-23441-00	HOLDER, HANDLE UPPER	2	2	
18	91314-08025	BOLT, HEXAGON SOCKET HEAD	4	4	
19	1TP-23408-00	STEERING LOCK ASSY	1	1	
20	90109-08195	BOLT	1	1	
21	90149-08055	SCREW	1	1	
22	1TP-23484-00	CAP, HANDLE LOCK	2	2	

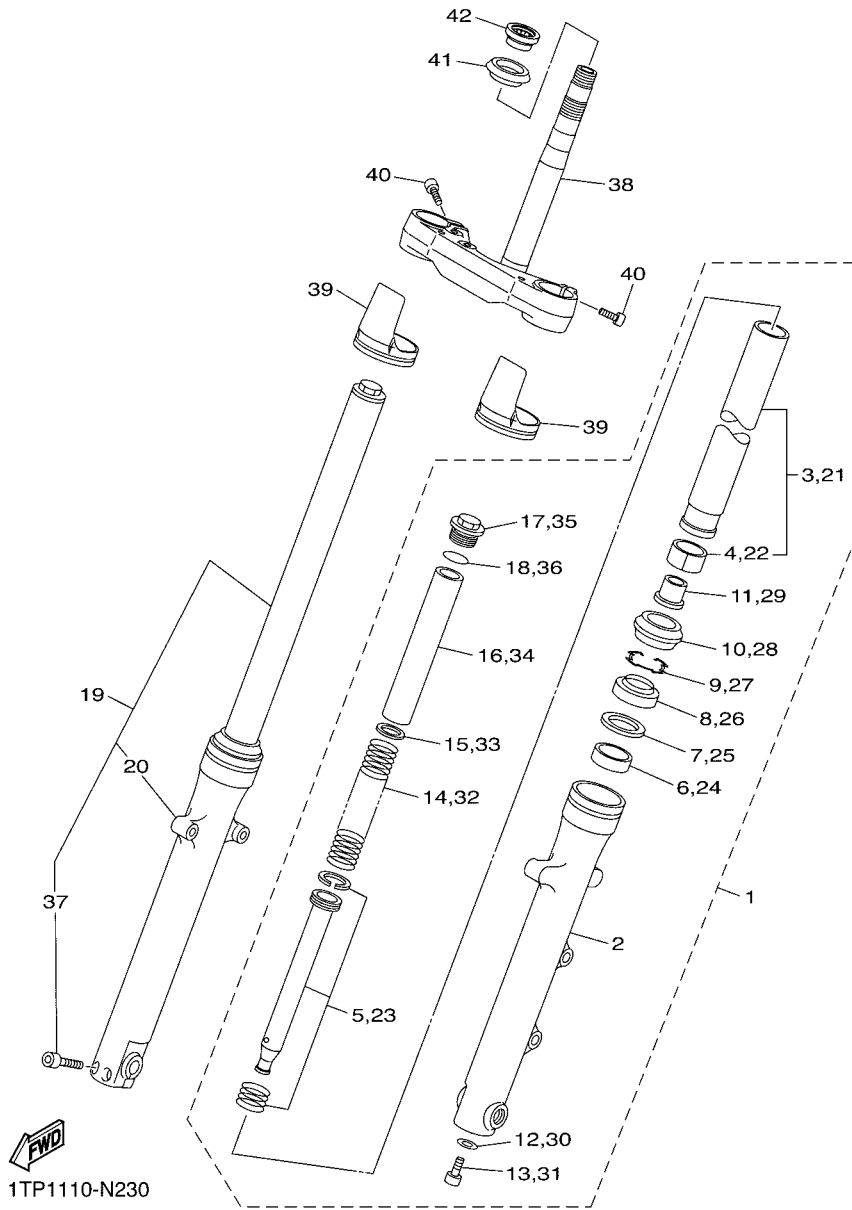

FIG. 23 FRONT FORK

REF. NO.	PART NO.	DESCRIPTION	1TP1	1TP2		REMARKS
1	1TP-23102-00	FRONT FORK ASSY (L.H)	1	1		
2	1TP-23126-00	.TUBE, OUTER (L.H)	1	1		
3	1TP-23110-00	.INNER TUBE COMP.1	1	1		
4	4FM-23171-40	..METAL, SLIDE	1	1		
5	1TP-23170-00	.CYLINDER COMP., FRONT FORK	1	1		
6	4FM-23125-40	..METAL, SLIDE 1	1	1		
7	1TP-23146-00	.WASHER, OIL SEAL	1	1		
8	4EB-23145-01	.OIL SEAL	1	1		
9	1TP-23156-00	.RING, SNAP	1	1		
10	4EB-23144-00	.SEAL, DUST	1	1		
11	1TP-23173-00	.SPINDLE, TAPER	1	1		
12	1TP-23158-00	.GASKET	1	1		
13	1TP-23181-00	.BOLT, HEXAGON SOCKET HEAD	1	1		
14	1TP-23141-00	.SPRING, FRONT FORK	1	1		
15	1TP-23149-00	.WASHER, SPRING UPPER	1	1		
16	1TP-23118-00	.SPACER	1	1		
17	1TP-23111-00	.BOLT, CAP	1	1		
18	1TP-23188-00	.O-RING	1	1		
19	1TP-23103-00	FRONT FORK ASSY (R.H)	1	1		
20	1TP-23136-00	.TUBE, OUTER (R.H)	1	1		
21	1TP-23110-00	.INNER TUBE COMP.1	1	1		
22	4FM-23171-40	..METAL, SLIDE	1	1		
23	1TP-23170-00	.CYLINDER COMP., FRONT FORK	1	1		
24	4FM-23125-40	..METAL, SLIDE 1	1	1		
25	1TP-23146-00	.WASHER, OIL SEAL	1	1		
26	4EB-23145-01	.OIL SEAL	1	1		
27	1TP-23156-00	.RING, SNAP	1	1		

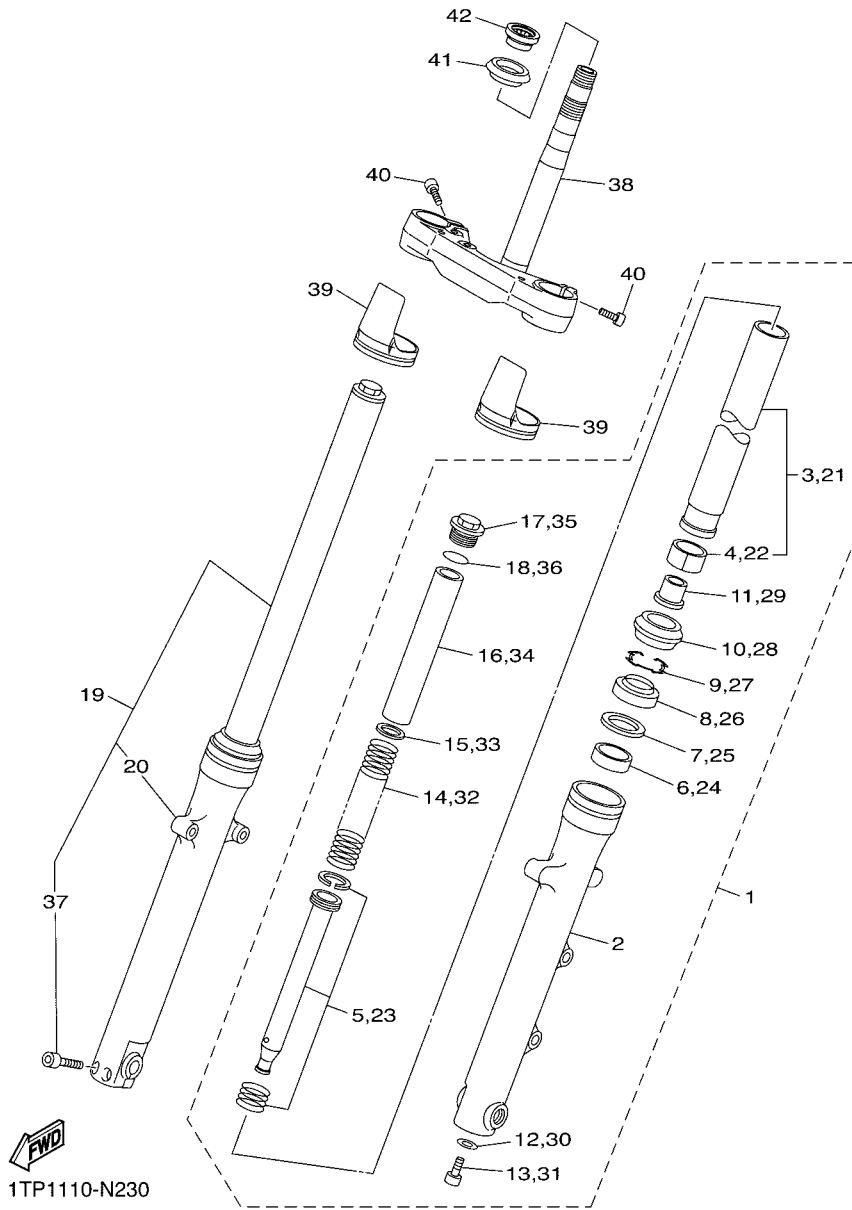
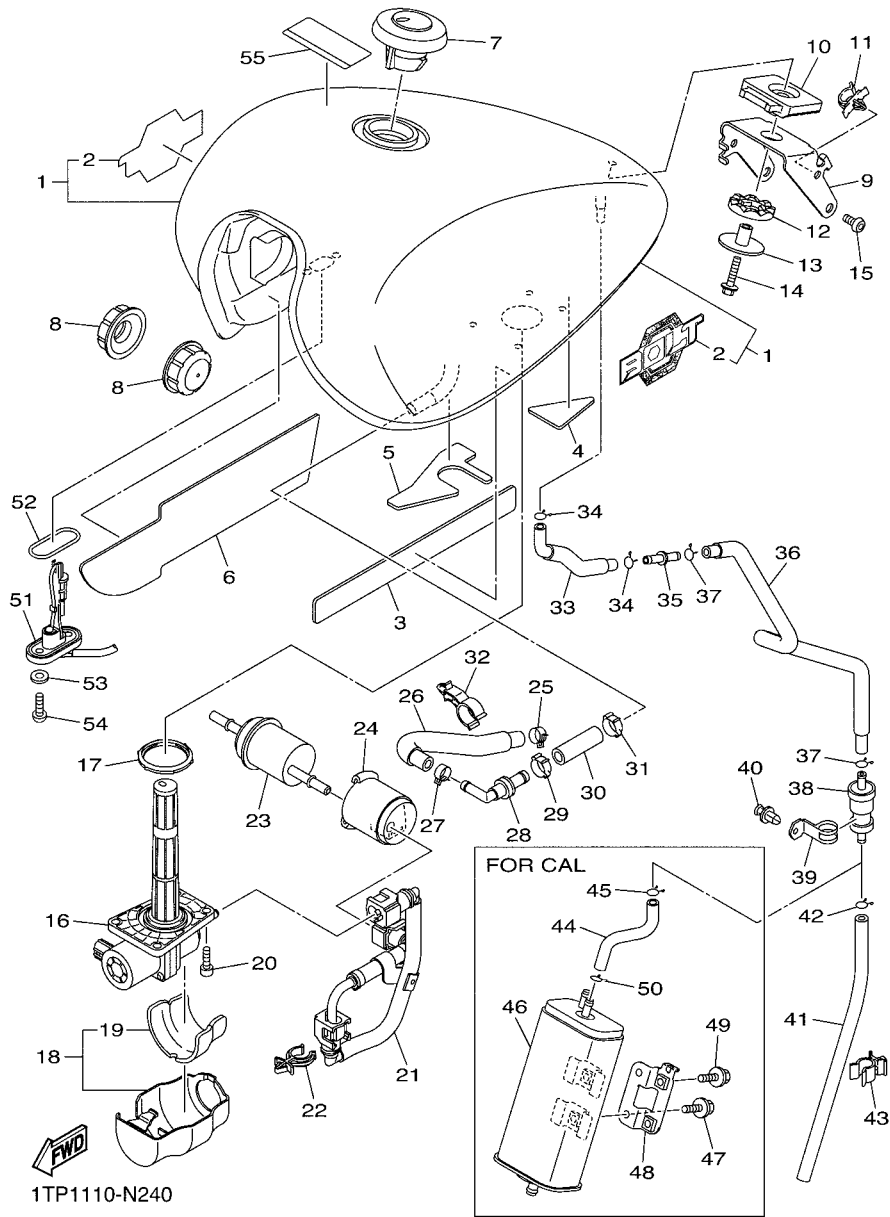

FIG. 23 FRONT FORK

REF. NO.	PART NO.	DESCRIPTION	1TP1	1TP2	REMARKS
28	4EB-23144-00	.SEAL, DUST	1	1	
29	1TP-23173-00	.SPINDLE, TAPER	1	1	
30	1TP-23158-00	.GASKET	1	1	
31	1TP-23181-00	.BOLT, HEXAGON SOCKET HEAD	1	1	
32	1TP-23141-00	.SPRING, FRONT FORK	1	1	
33	1TP-23149-00	.WASHER, SPRING UPPER	1	1	
34	1TP-23118-00	.SPACER	1	1	
35	1TP-23111-00	.BOLT, CAP	1	1	
36	1TP-23188-00	.O-RING	1	1	
37	1TP-2311H-00	.FORK BOLT	2	2	
38	1TP-23340-00	UNDER BRACKET COMP.	1	1	
39	4PU-2331G-00	COVER	2	2	
40	91314-10020	BOLT, HEXAGON SOCKET HEAD	4	4	
41	3FV-23462-00	SEAL, STEERING	1	1	
42	93399-99932	BEARING	1	1	



1TP1110-N240

FIG. 24 FUEL TANK

REF. NO.	PART NO.	DESCRIPTION	1TP1	1TP2	REMARKS
1	1TP-YK241-00-P1	FUEL TANK COMP.	1	1	UR FOR SMX
	1TP-Y2410-00-01	FUEL TANK COMP.	1	1	UR FOR BWC1
2	1TP-24244-00	.GRAPHIC, FUEL TANK 1	2	2	FOR BWC1
3	1TP-2414H-00	DAMPER, PLATE 1	1	1	
4	1TP-2414J-00	DAMPER, PLATE 2	1	1	
5	1TP-2414K-00	DAMPER, PLATE 3	1	1	
6	1TP-2414I-00	PROTECTOR, FUEL TANK	1	1	
7	4NK-24602-20	CAP ASSY	1	1	
8	1TP-24181-00	DAMPER, LOCATING 1	2	2	
9	1TP-2413Y-00	BRACKET, TANK FITTING	1	1	
10	1TP-24182-00	DAMPER, LOCATING 2	1	1	
11	90464-14001	CLAMP	1	1	
12	1TP-24183-00	DAMPER, LOCATING 3	1	1	
13	90387-06177	COLLAR	1	1	
14	95812-06030	BOLT, FLANGE	1	1	
15	92012-08012	BOLT, BUTTON HEAD	2	2	
16	1TP-13907-00	FUEL PUMP COMP.	1	1	
17	1TP-24486-00	O-RING	1	1	
18	1TP-24474-00	COVER	1	1	
19	1TP-2414N-00	.DAMPER, PLATE 4	1	1	
20	91312-05016	BOLT	4	4	
21	1TP-24330-00	FUEL PIPE ASSY. 2	1	1	
22	90464-16240	CLAMP	1	1	
23	1TP-13915-00	FILTER	1	1	
24	1TP-24398-00	BAND 1	1	1	
25	90467-12003	CLIP	1	1	
26	1TP-24315-00	PIPE 5	1	1	

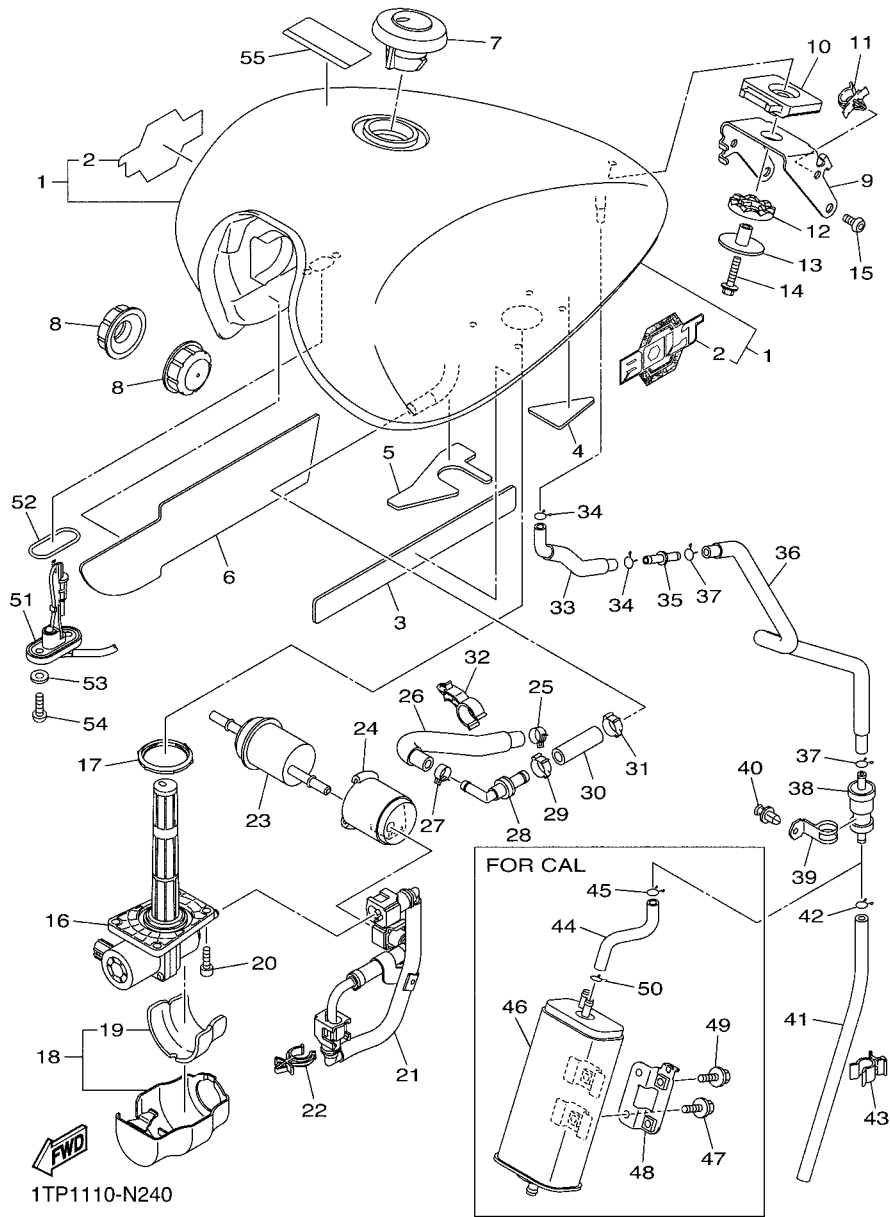

1TP1110-N240

FIG. 24 FUEL TANK

REF. NO.	PART NO.	DESCRIPTION	1TP1	1TP2	REMARKS
27	90467-12003	CLIP	1	1	
28	1TP-14860-00	CHECK VALVE ASSY	1	1	
29	90467-150A6	CLIP	1	1	
30	1TP-24314-00	PIPE 4	1	1	
31	90467-150A6	CLIP	1	1	
32	90464-17009	CLAMP	1	1	
33	1TP-24313-00	PIPE 3	1	1	
34	90467-09103	CLIP	2	2	
35	4XY-14568-00	JOINT	1	1	
36	1TP-24316-00	PIPE 6	1	1	
37	90467-09103	CLIP	2	2	
38	5PX-24180-00	ROLL OVER VALVE ASSY	1	1	
39	1TP-24136-00	CLAMP 2	1	1	
40	90269-05005	RIVET	1	1	
41	90445-11730	HOSE (L280)	1		
42	90467-09103	CLIP	1		
43	90464-12015	CLAMP	1		
44	1TP-2486A-00	PIPE 1	1		FOR CALIFORNIA
45	90467-09103	CLIP	1		FOR CALIFORNIA
46	5PX-24170-00	CANISTER ASSY	1		FOR CALIFORNIA
47	95802-06010	BOLT, FLANGE	2		FOR CALIFORNIA
48	1TP-2413X-00	PLATE	1		FOR CALIFORNIA
49	95827-06012	BOLT, FLANGE	2		FOR CALIFORNIA
50	90467-09103	CLIP	1		FOR CALIFORNIA
51	1TP-85752-00	SENDER UNIT ASSY, FUEL METER	1	1	
52	42X-85753-00	GASKET, SENDER UNIT	1	1	
53	90202-05193	WASHER, PLATE	2	2	

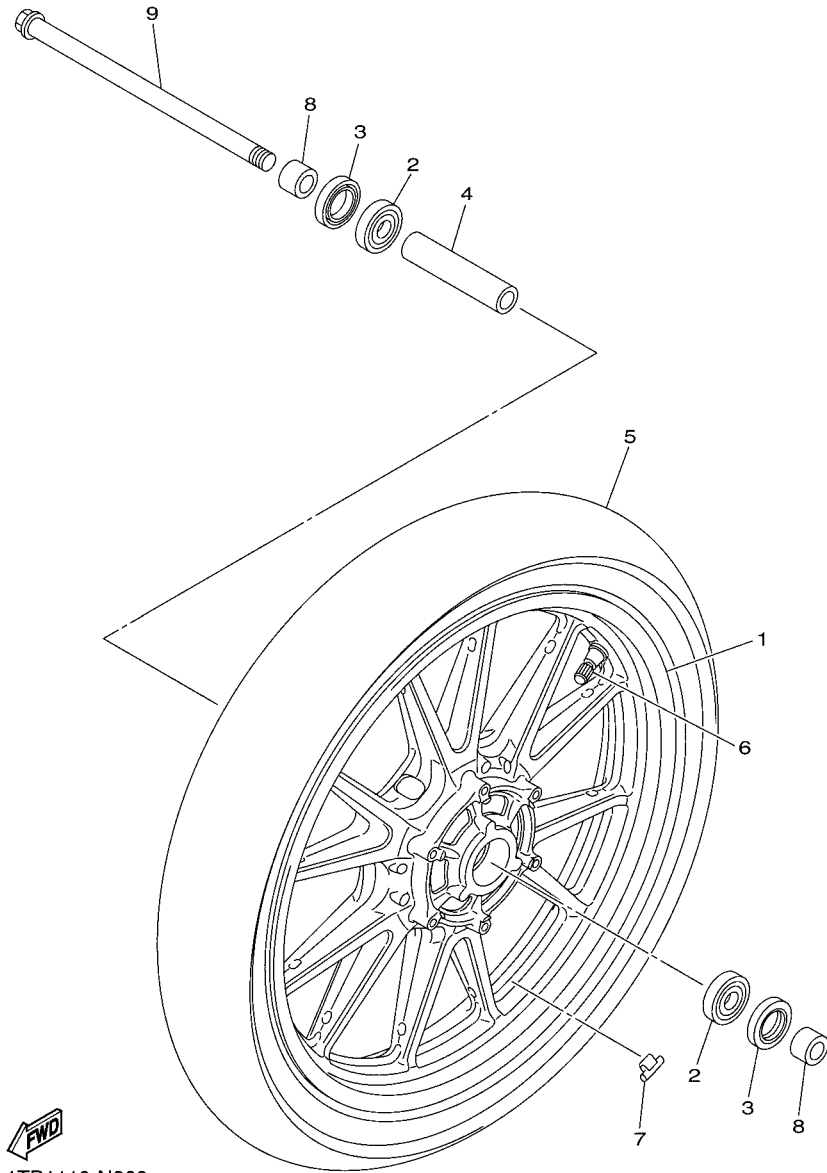

1TP1110-N260

FIG. 26 FRONT WHEEL

REF. NO.	PART NO.	DESCRIPTION	1TP1	1TP2	REMARKS
1	1TP-25168-00	CAST WHEEL, FRONT	1	1	
2	93306-30317	BEARING	2	2	
3	93102-28022	OIL SEAL	2	2	
4	90387-172A5	COLLAR	1	1	
5	94110-19025	TIRE(100/90-19 M/C 57H EXEDRA)	1	1	BRIDGESTONE
6	93900-00030	VALVE, RIM (TR412)	1	1	TAIHEIYO
7	5MT-25398-00	BALANCER, WHEEL (10G)	1	1	UN
	5MT-25398-10	BALANCER, WHEEL (20G)	1	1	UN
	5MT-25398-20	BALANCER, WHEEL (30G)	1	1	UN
8	90387-173R6	COLLAR	2	2	
9	3MA-25181-10	AXLE, WHEEL	1	1	

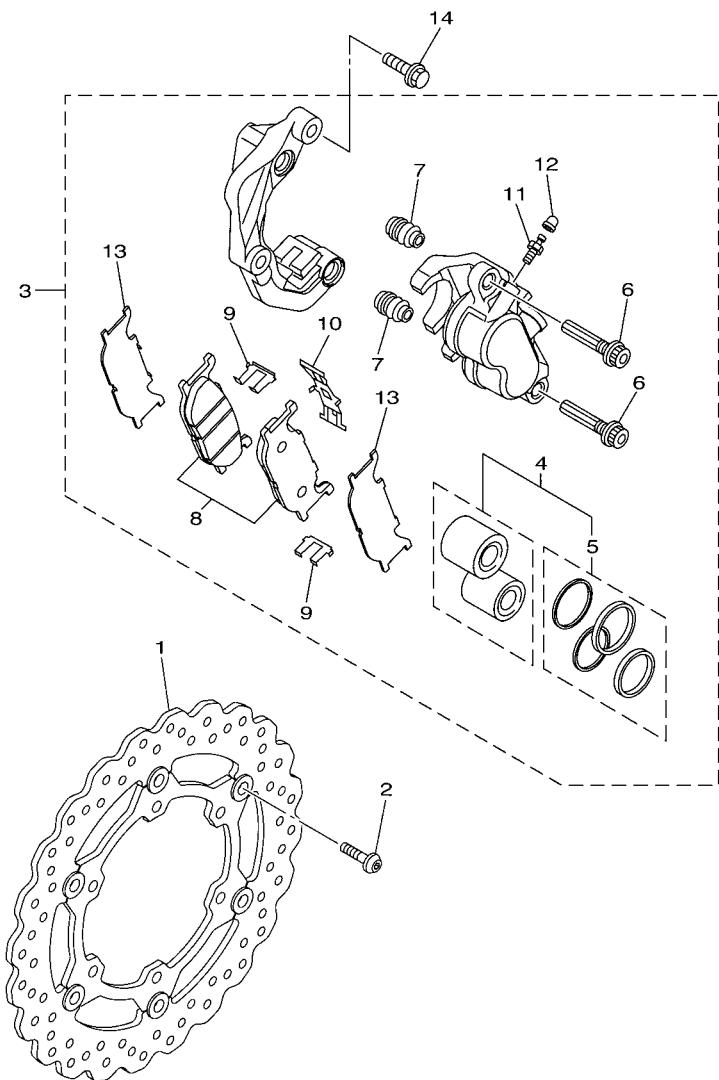

1TP1110-N270

FIG. 27 FRONT BRAKE CALIPER

REF. NO.	PART NO.	DESCRIPTION	TTP1	TTP2	REMARKS
1	1TP-2581T-00	DISK BRAKE ASSY	1	1	
2	90109-083G4	BOLT	6	6	
3	27D-2580T-00	CALIPER ASSY (LEFT)	1	1	
4	3YX-W0057-00	.PISTON ASSY, CALIPER	1	1	
5	3JB-W0047-00	..CALIPER SEAL KIT	1	1	
6	5JW-25914-10	.PIN, SLIDE	2	2	
7	4TT-25937-00	.BOOT 2	2	2	
8	5S7-W0045-00	.BRAKE PAD KIT	1	1	
9	4BP-25919-00	.SUPPORT, PAD	2	2	
10	3YX-25929-00	.SPRING, ANTI RATTLE	1	1	
11	47X-25824-01	.SCREW, BLEED	1	1	
12	1D7-25825-00	.CAP	1	1	
13	4DN-25827-00	.SHIM, CALIPER	2	2	
14	90105-10638	BOLT, FLANGE	2	2	

FIG. 28 REAR WHEEL

REF. NO.	PART NO.	DESCRIPTION	TTP1	TTP2	REMARKS
1	1TP-25338-00	CAST WHEEL, REAR	1	1	
2	93306-20417	BEARING	2	2	
3	93106-28023	OIL SEAL	1	1	
4	1TP-25317-00	SPACER, BEARING	1	1	
5	4WM-25364-00	DAMPER	6	6	
6	1TP-25383-00	COLLAR, WHEEL	1	1	
7	94115-16025	TIRE (150/80B16 M/C 71H EXEDR)	1	1	BRIDGESTONE
8	93900-00030	VALVE, RIM (TR412)	1	1	TAIHEIYO
9	5MT-25398-00	BALANCER, WHEEL (10G)	1	1	UN
	5MT-25398-10	BALANCER, WHEEL (20G)	1	1	UN
	5MT-25398-20	BALANCER, WHEEL (30G)	1	1	UN
10	1TP-25366-00	CLUTCH, HUB	1	1	
11	93311-32698	BEARING	1	1	
12	93306-30437	BEARING	1	1	
13	99009-52500	CIRCLIP	1	1	
14	93450-35163	CIRCLIP	1	1	
15	93106-30004	OIL SEAL	1	1	
16	4WM-25376-10	COLLAR, WHEEL	1	1	
17	95612-12630	BOLT, STUD	5	5	
18	1TP-25470-00	SPROCKET, DRIVEN (70T)	1	1	
19	95614-12100	NUT, U	5	5	
20	90201-12045	WASHER, PLATE	5	5	
21	1TP-46241-00	V-BELT	1	1	
22	1TP-25388-00	PULLER, CHAIN 1	2	2	
23	90101-08777	BOLT	2	2	
24	95317-08700	NUT	2	2	
25	90387-20034	COLLAR	1	1	

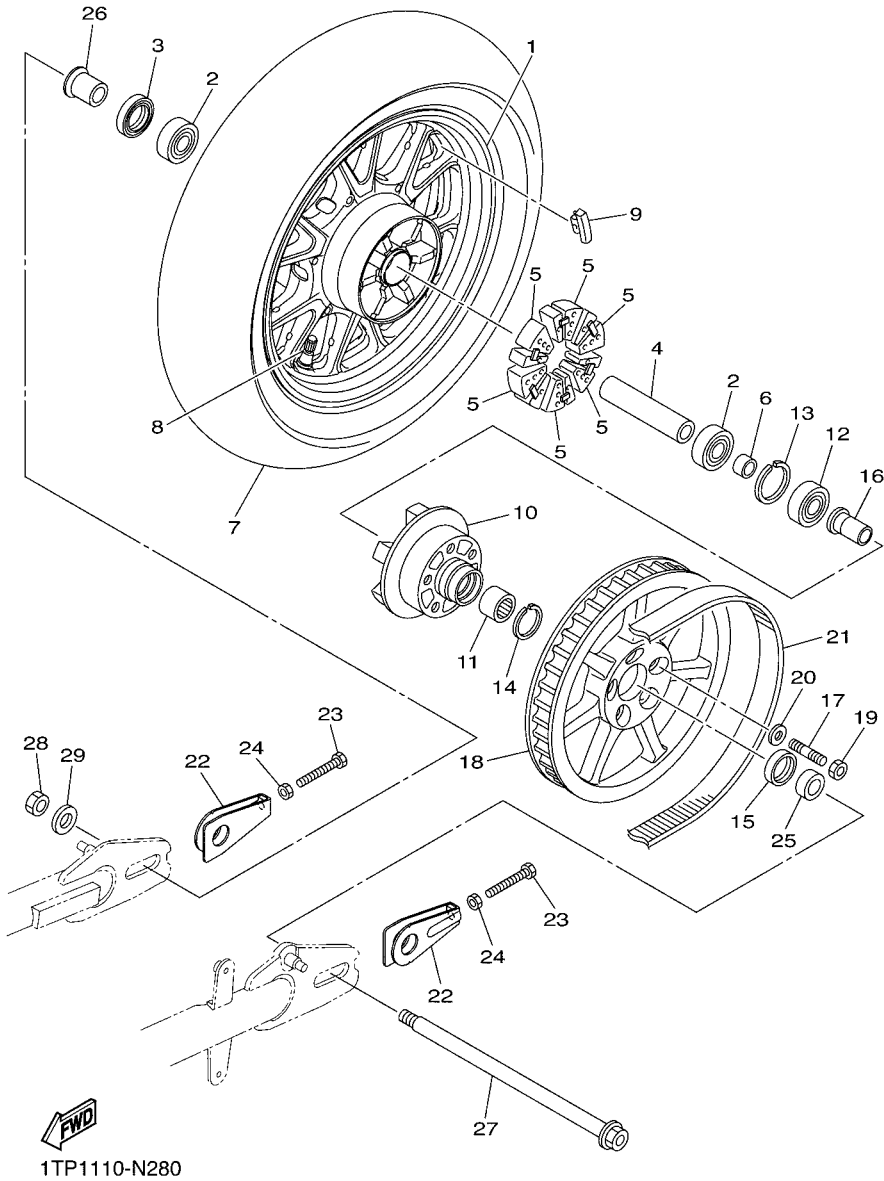

1TP1110-N280

FIG. 28 REAR WHEEL

REF. NO.	PART NO.	DESCRIPTION	TTP1	TTP2				REMARKS
26	90387-202U8	COLLAR	1	1				
27	1TP-25381-00	AXLE, WHEEL	1	1				
28	90185-18009	NUT, SELF-LOCKING	1	1				
29	90201-18020	WASHER, PLATE	1	1				

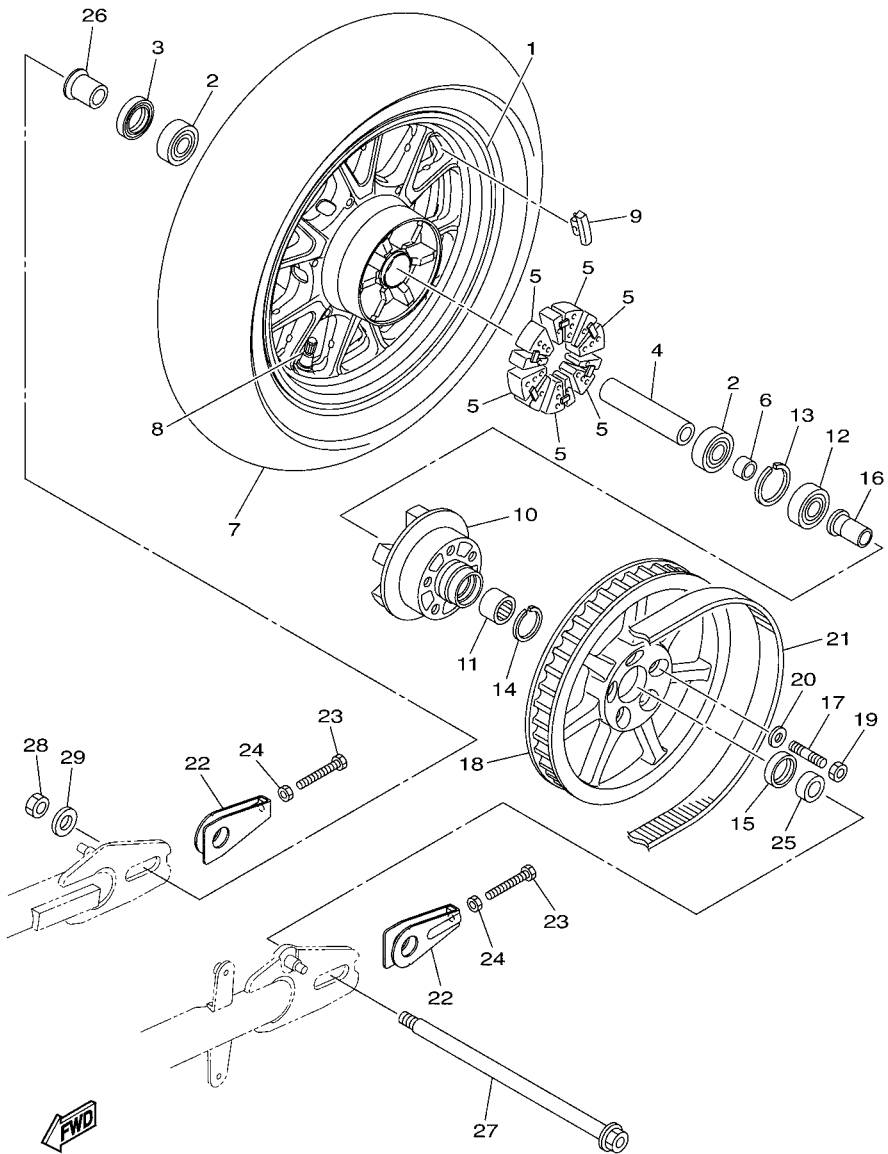

1TP1110-N280

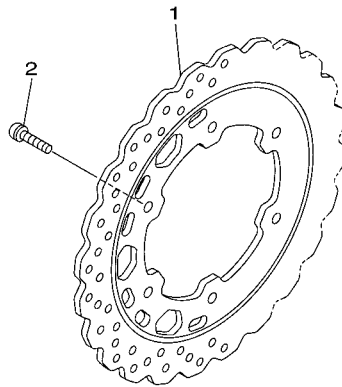
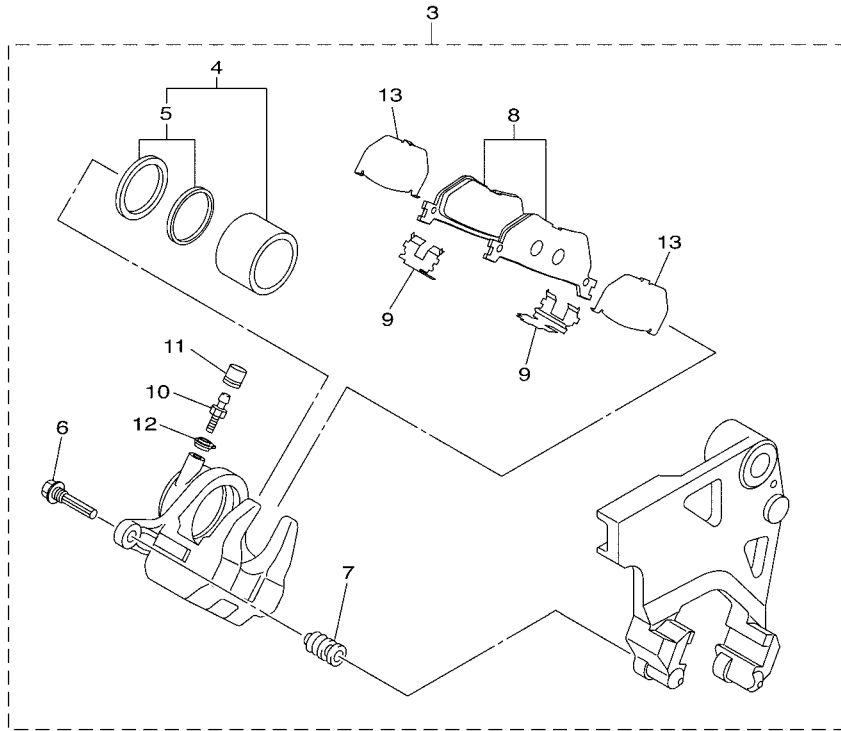

1TP1110-N290

FIG. 29 REAR BRAKE CALIPER

REF. NO.	PART NO.	DESCRIPTION	1TP1	1TP2		REMARKS
1	1TP-2582W-00	DISK, REAR BRAKE 2	1	1		
2	90109-083G4	BOLT	6	6		
3	1TP-2580W-00	CALIPER ASSY, REAR 2	1	1		
4	1D7-W0057-00	.PISTON ASSY, CALIPER	1	1		
5	5JW-W0047-00	..CALIPER SEAL KIT	1	1		
6	3P6-25914-00	.PIN, SLIDE	2	2		
7	4TT-25937-00	.BOOT 2	2	2		
8	1D7-W0046-00	.BRAKE PAD KIT 2	1	1		
9	1D7-25919-00	.SUPPORT, PAD	2	2		
10	5GM-25824-00	.SCREW, BLEED	1	1		
11	1D7-25825-00	.CAP	1	1		
12	5GM-25975-00	.RUBBER, BUSHING	1	1		
13	5GJ-25827-00	.SHIM, CALIPER	2	2		

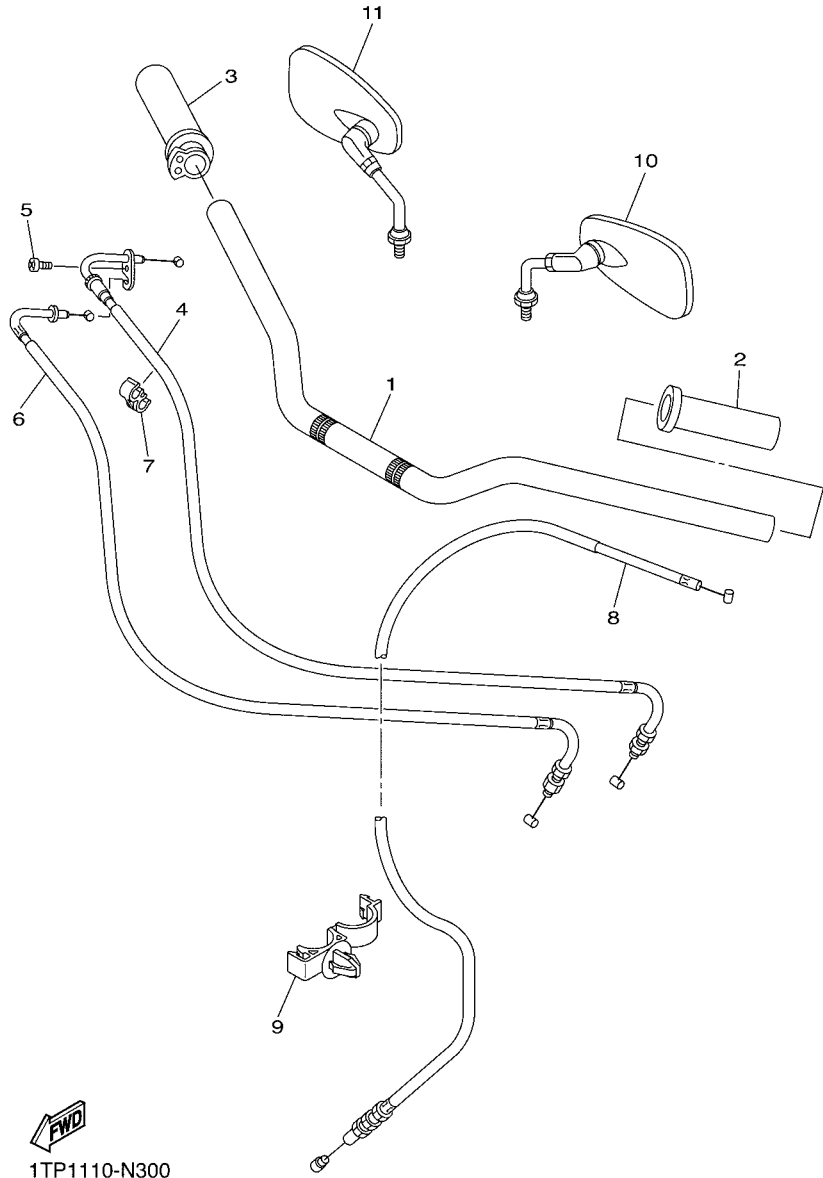

1TP1110-N300

FIG. 30 STEERING HANDLE & CABLE

REF. NO.	PART NO.	DESCRIPTION	1TP1	1TP2		REMARKS
1	1TP-26111-00	HANDLEBAR	1	1		
2	1TP-26241-00	GRIP	1	1		
3	1TP-26240-00	GRIP ASSY	1	1		
4	1TP-26311-00	CABLE, THROTTLE 1	1	1		
5	98507-05016	SCREW, PAN HEAD	1	1		
6	1TP-26312-00	CABLE, THROTTLE 2	1	1		
7	90464-06214	CLAMP	1	1		
8	1TP-26335-00	CABLE, CLUTCH	1	1		
9	90464-17003	CLAMP	1	1		
10	1TP-26280-00	REAR VIEW MIRROR ASSY (LEFT)	1	1		
11	1D7-26290-00	REAR VIEW MIRROR ASSY (RIGHT)	1	1		

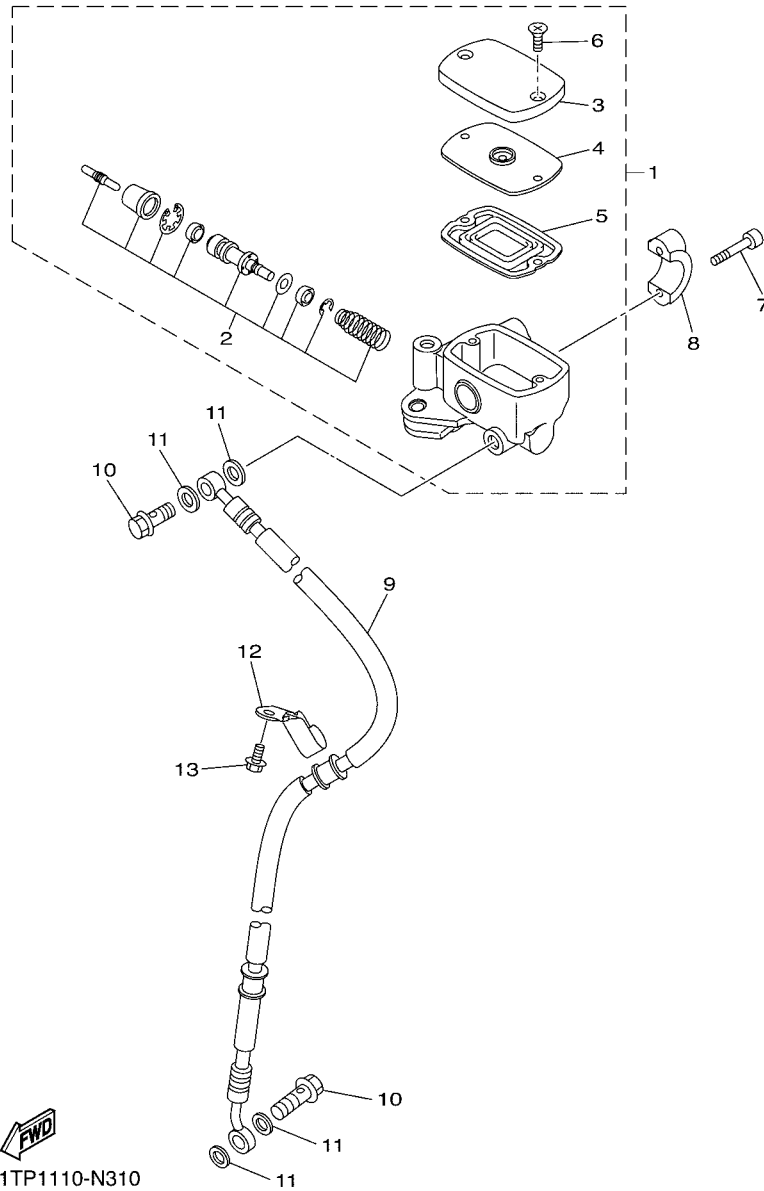
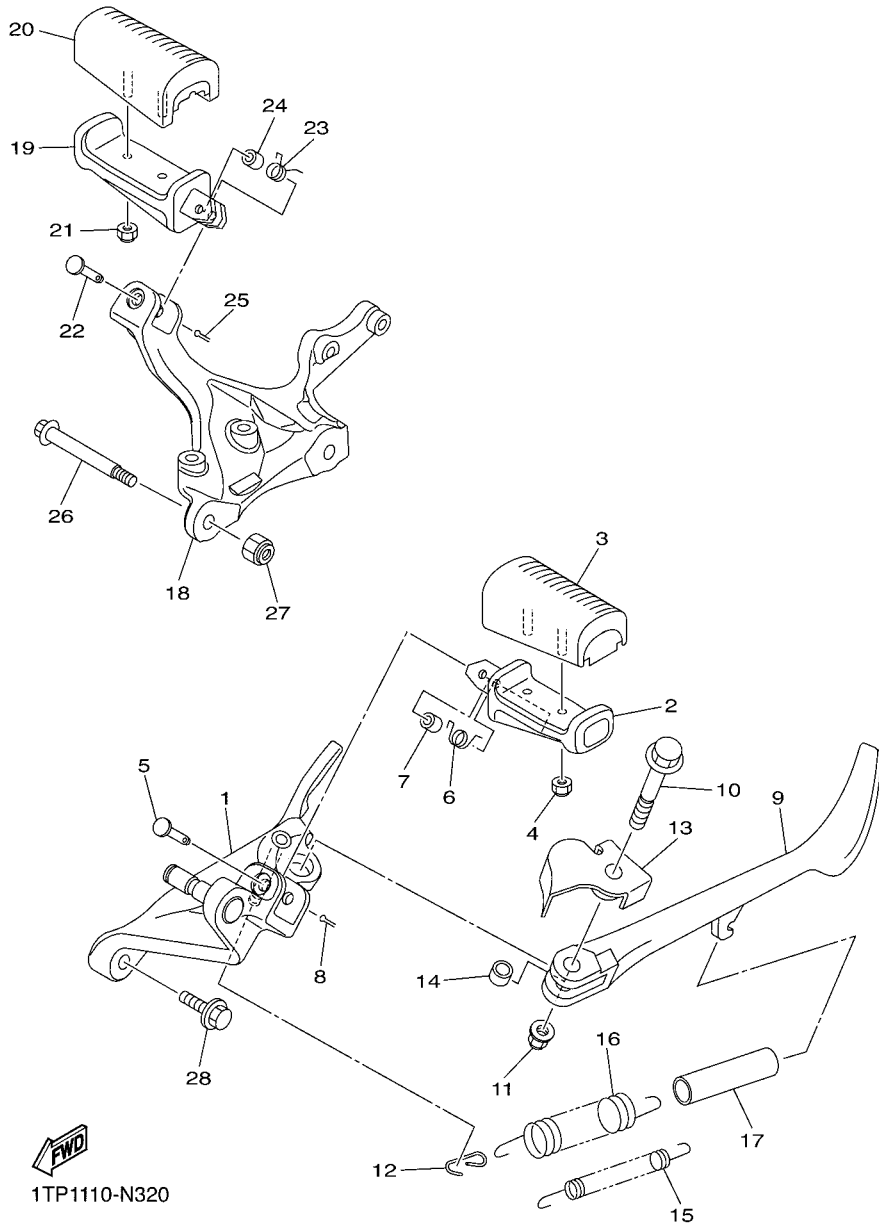

FIG. 31 FRONT MASTER CYLINDER

REF. NO.	PART NO.	DESCRIPTION			REMARKS
			1TP1	1TP2	
1	1TP-2580A-00	MASTER CYLINDER SUB ASSY 2	1	1	
2	1TP-25807-00	.CYLINDER KIT, MASTER	1	1	
3	4B5-25852-00	.CAP, RESERVOIR	1	1	
4	4B5-25855-00	.BUSH, DIAPHRAGM	1	1	
5	4B5-25854-00	.DIAPHRAGM, RESERVOIR	1	1	
6	5VS-2589H-00	.SCREW	2	2	
7	5VS-26332-00	BOLT	2	2	
8	3D8-25867-00	BRACKET, MASTER CYLINDER	1	1	
9	1TP-25872-00	HOSE, BRAKE 1	1	1	
10	90401-10020	BOLT, UNION	2	2	
11	90430-10005	GASKET	4	4	
12	1TP-25886-00	HOLDER, BRAKE HOSE	1	1	
13	95027-06010	BOLT, FLANGE	1	1	



1TP1110-N320

FIG. 32 STAND & FOOTREST

REF. NO.	PART NO.	DESCRIPTION	1TP1	1TP2	REMARKS
1	1TP-27411-00	FOOTREST 1	1	1	
2	1TP-27451-00	FOOTREST	1	1	
3	4VR-27413-00	COVER, FOOTREST	1	1	
4	95607-06100	NUT, U	2	2	
5	90240-08145	PIN, CLEVIS	1	1	
6	90508-18054	SPRING, TORSION	1	1	
7	90387-087K5	COLLAR	1	1	
8	91401-25015	PIN, COTTER	1	1	
9	1TP-27311-00	STAND, SIDE	1	1	
10	90105-10426	BOLT, FLANGE	1	1	
11	90185-10008	NUT, SELF-LOCKING	1	1	
12	1TP-27315-00	LINK, SIDE STAND	1	1	
13	1TP-27322-00	WASHER	1	1	
14	90387-10020	COLLAR	1	1	
15	90506-23015	SPRING, TENSION	1	1	
16	90506-29006	SPRING, TENSION	1	1	
17	90445-16641	HOSE (L60)	1	1	
18	1TP-27421-00	FOOTREST 2	1	1	
19	1TP-27461-00	FOOTREST	1	1	
20	4VR-27413-00	COVER, FOOTREST	1	1	
21	95607-06100	NUT, U	2	2	
22	90240-08145	PIN, CLEVIS	1	1	
23	90508-18054	SPRING, TORSION	1	1	
24	90387-087K5	COLLAR	1	1	
25	91401-25015	PIN, COTTER	1	1	
26	90105-10364	BOLT, FLANGE	2	2	
27	90185-10008	NUT, SELF-LOCKING	2	2	

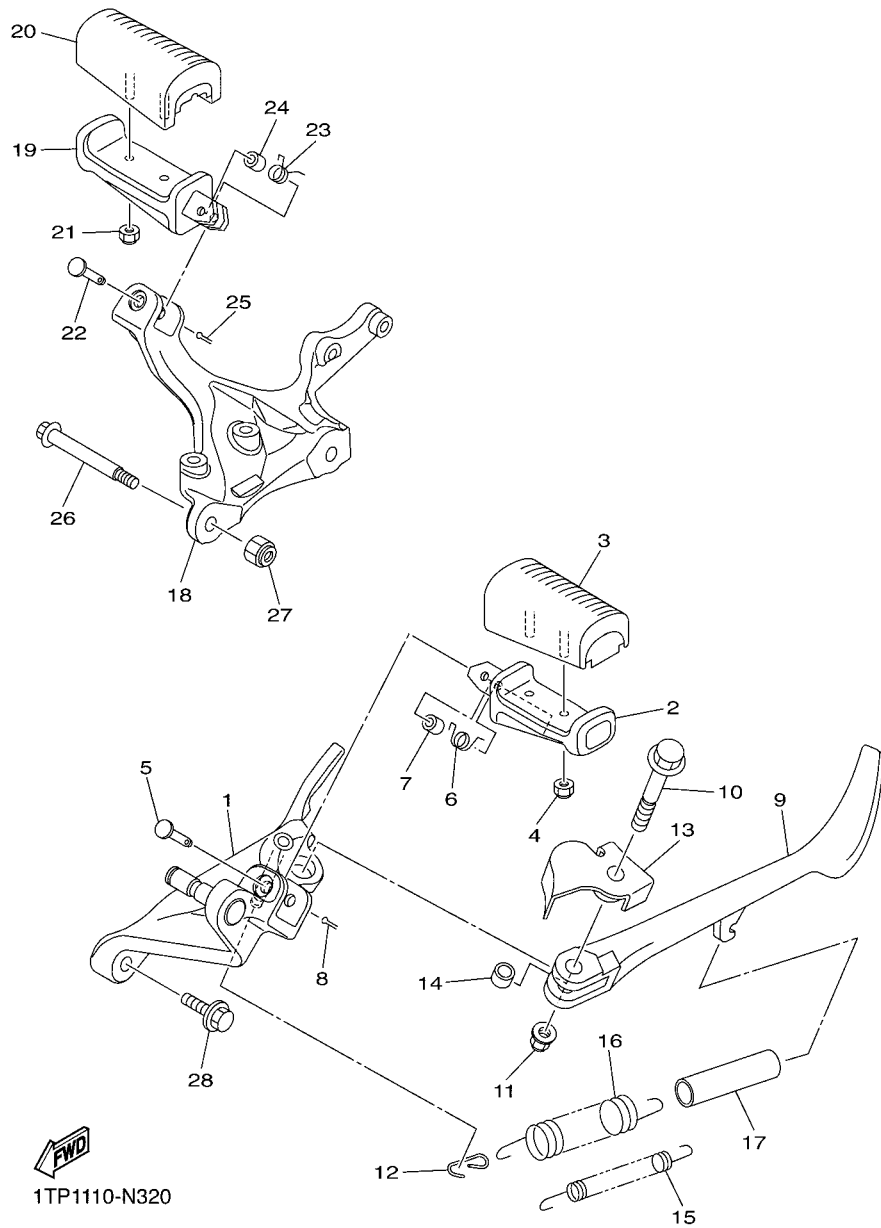

FIG. 32 STAND & FOOTREST

REF. NO.	PART NO.	DESCRIPTION	1TP1	1TP2		REMARKS
28	90105-10424	BOLT, FLANGE	2	2		
<hr style="border-top: 1px dashed black;"/>						
<hr style="border-top: 1px dashed black;"/>						
<hr style="border-top: 1px dashed black;"/>						
<hr style="border-top: 1px dashed black;"/>						
<hr style="border-top: 1px dashed black;"/>						
<hr style="border-top: 1px dashed black;"/>						
<hr style="border-top: 1px dashed black;"/>						
<hr style="border-top: 1px dashed black;"/>						
<hr style="border-top: 1px dashed black;"/>						

FIG. 33 REAR MASTER CYLINDER

REF. NO.	PART NO.	DESCRIPTION	TTP1	TTP2	REMARKS
1	1TP-27200-00	PEDAL, BRAKE	1	1	
2	5VN-18113-00	.COVER, SHIFT PEDAL	1	1	
3	1TP-27243-00	BOSS, BRAKE PEDAL	1	1	
4	95027-08035	BOLT, FLANGE	2	2	
5	1TP-27216-00	SPRING, RETURN	1	1	
6	1TP-27262-00	LEVER	1	1	
7	97002-06020	BOLT	1	1	
8	90240-08124	PIN, CLEVIS	1	1	
9	90201-08083	WASHER, PLATE	1	1	
10	91401-20012	PIN, COTTER	1	1	
11	1TP-2583V-00	RR. MASTER CYLINDER ASSY.	1	1	
12	1TP-25808-00	.CYLINDER KIT, MASTER	1	1	
13	4BP-2582A-00	.JOINT	1	1	
14	4BP-2585F-01	.O-RING	1	1	
15	4BP-27222-02	.JOINT	1	1	
16	90170-08010	.NUT	2	2	
17	95027-08030	BOLT, FLANGE	2	2	
18	90401-10020	BOLT, UNION	2	2	
19	90430-10005	GASKET	4	4	
20	1TP-2581J-00	HOSE, BRAKE 4	1	1	
21	1TP-2588F-00	HOLDER, BRAKE HOSE 5	1	1	
22	95022-06016	BOLT, FLANGE	1	1	
23	1TP-2587A-00	HOLDER, BRAKE HOSE	1	1	
24	95022-06016	BOLT, FLANGE	2	2	
25	31A-25894-10	TANK, RESERVOIR	1	1	
26	360-25854-01	DIAPHRAGM, RESERVOIR	1	1	
27	2GU-25855-00	BUSH,DIAPHRAGM	1	1	

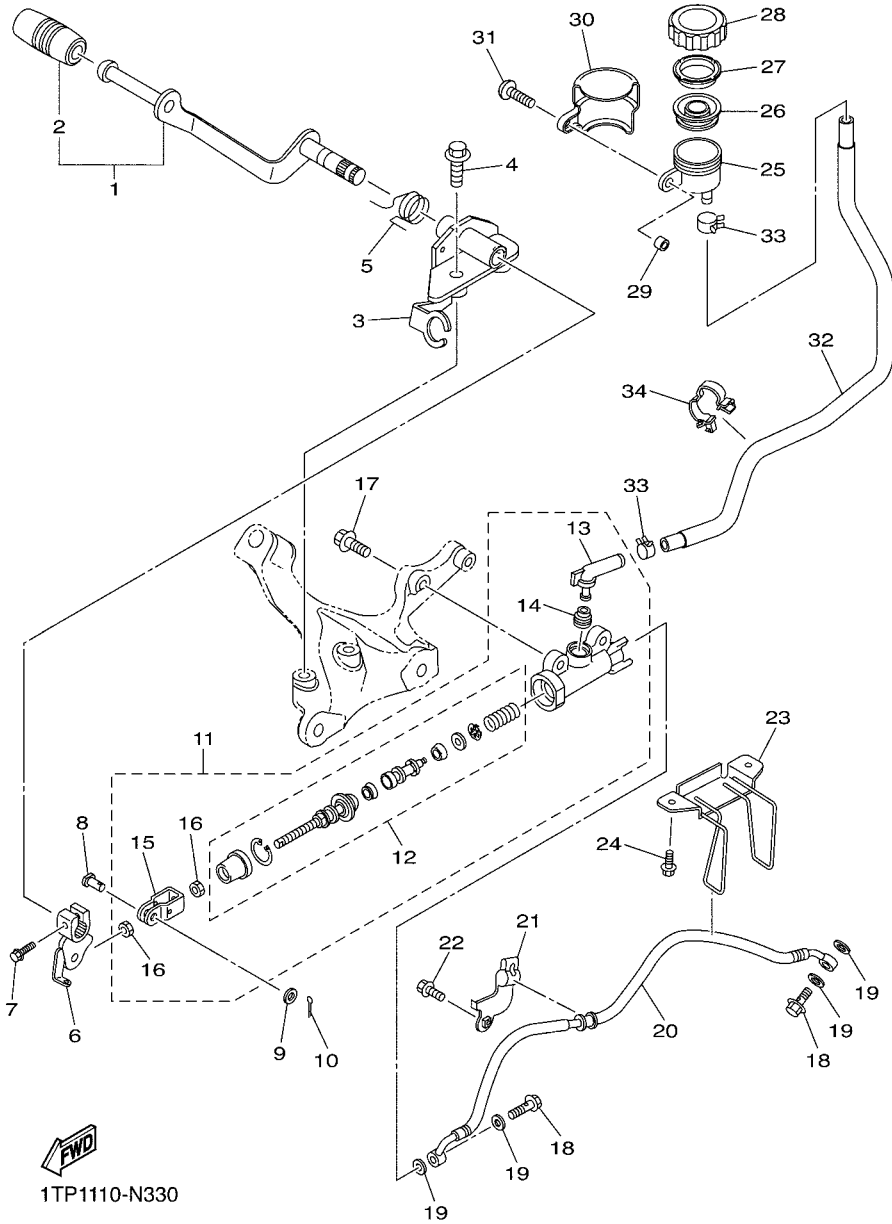
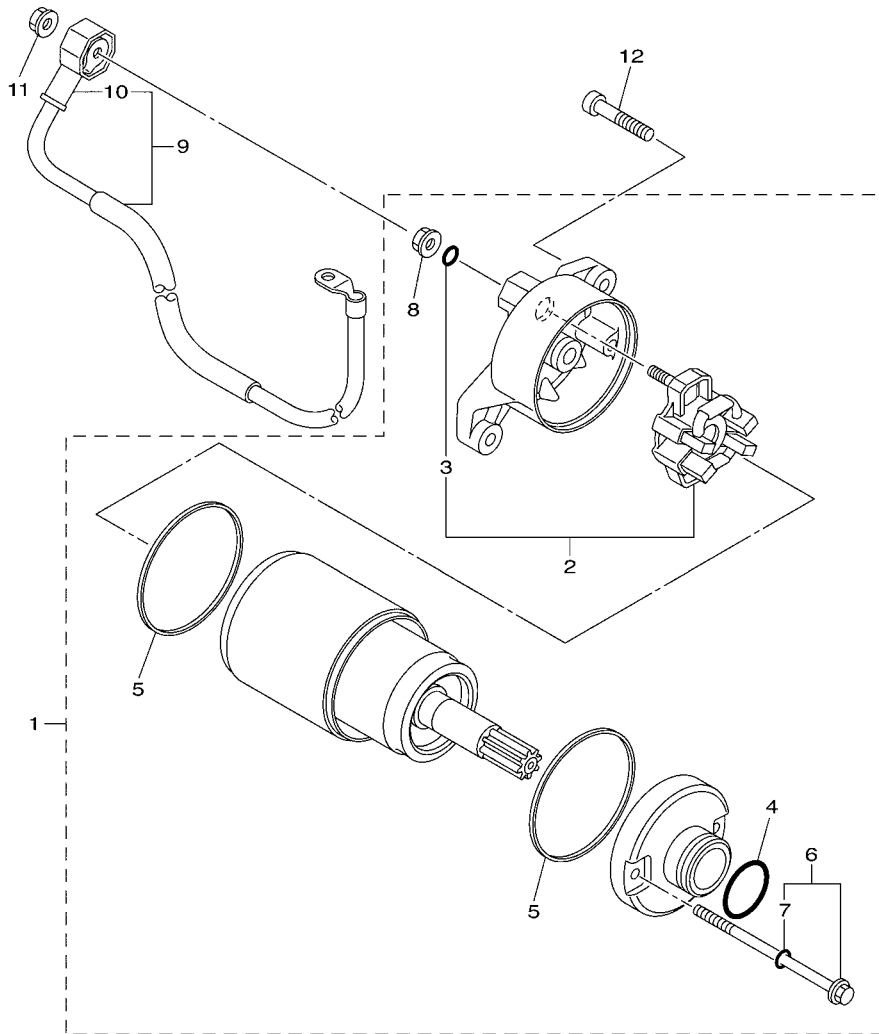

FIG. 35 STARTING MOTOR

REF. NO.	PART NO.	DESCRIPTION	1TP1	1TP2	REMARKS
1	1TP-81890-00	MOTOR ASSY	1	1	
2	4B5-81840-00	.BRUSH HOLDER ASSY	1	1	
3	3TB-81847-00	..O-RING	1	1	
4	1FK-81847-00	.O-RING	1	1	
5	35C-81844-00	.GASKET	2	2	
6	28P-81826-00	.BOLT	2	2	
7	3TB-81847-00	..O-RING	1	1	
8	4XV-8182A-00	.NUT	1	1	
9	1TP-81815-00	CORD, STARTER MOTOR	1	1	
10	4B5-81871-00	.CAP	1	1	
11	4XV-8182A-00	NUT	1	1	
12	91314-06030	BOLT, HEXAGON SOCKET HEAD	2	2	



1TP1110-N350

FIG. 36 FLASHER LIGHT

REF. NO.	PART NO.	DESCRIPTION	TTP1	TTP2	REMARKS
1	1TP-83310-00	FRONT FLASHER LIGHT ASSY 1	1	1	
2	5VN-83311-00	.BULB, FLASHER (12V-23/8W)	1	1	
3	5PX-83312-10	.LENS, FLASHER	1	1	
4	5PX-83313-00	.GASKET, FLASHER LENS	1	1	
5	97704-40625	.SCREW, TAPPING	2	2	
6	5PX-83348-00	.WASHER	2	2	
7	1TP-83320-00	FRONT FLASHER LIGHT ASSY 2	1	1	
8	5VN-83311-00	.BULB, FLASHER (12V-23/8W)	1	1	
9	5PX-83312-10	.LENS, FLASHER	1	1	
10	5PX-83313-00	.GASKET, FLASHER LENS	1	1	
11	97704-40625	.SCREW, TAPPING	2	2	
12	5PX-83348-00	.WASHER	2	2	
13	95707-06500	NUT, FLANGE	2	2	
14	90387-06076	COLLAR	2	2	
15	90201-06045	WASHER, PLATE	2	2	
16	95027-06025	BOLT, FLANGE	2	2	
17	90387-08085	COLLAR	2	2	
18	91317-08025	BOLT	2	2	
19	90201-083P5	WASHER, PLATE	1	1	
20	5C7-83330-10	REAR FLASHER LIGHT ASSY 1	1	1	
21	5VN-83331-00	.BULB, FLASHER (12V-21W)	1	1	
22	5PX-83342-10	.LENS, FLASHER 2	1	1	
23	5PX-83313-00	.GASKET, FLASHER LENS	1	1	
24	97704-40625	.SCREW, TAPPING	2	2	
25	5PX-83348-00	.WASHER	2	2	
26	5C7-83340-10	REAR FLASHER LIGHT ASSY 2	1	1	
27	5VN-83331-00	.BULB, FLASHER (12V-21W)	1	1	

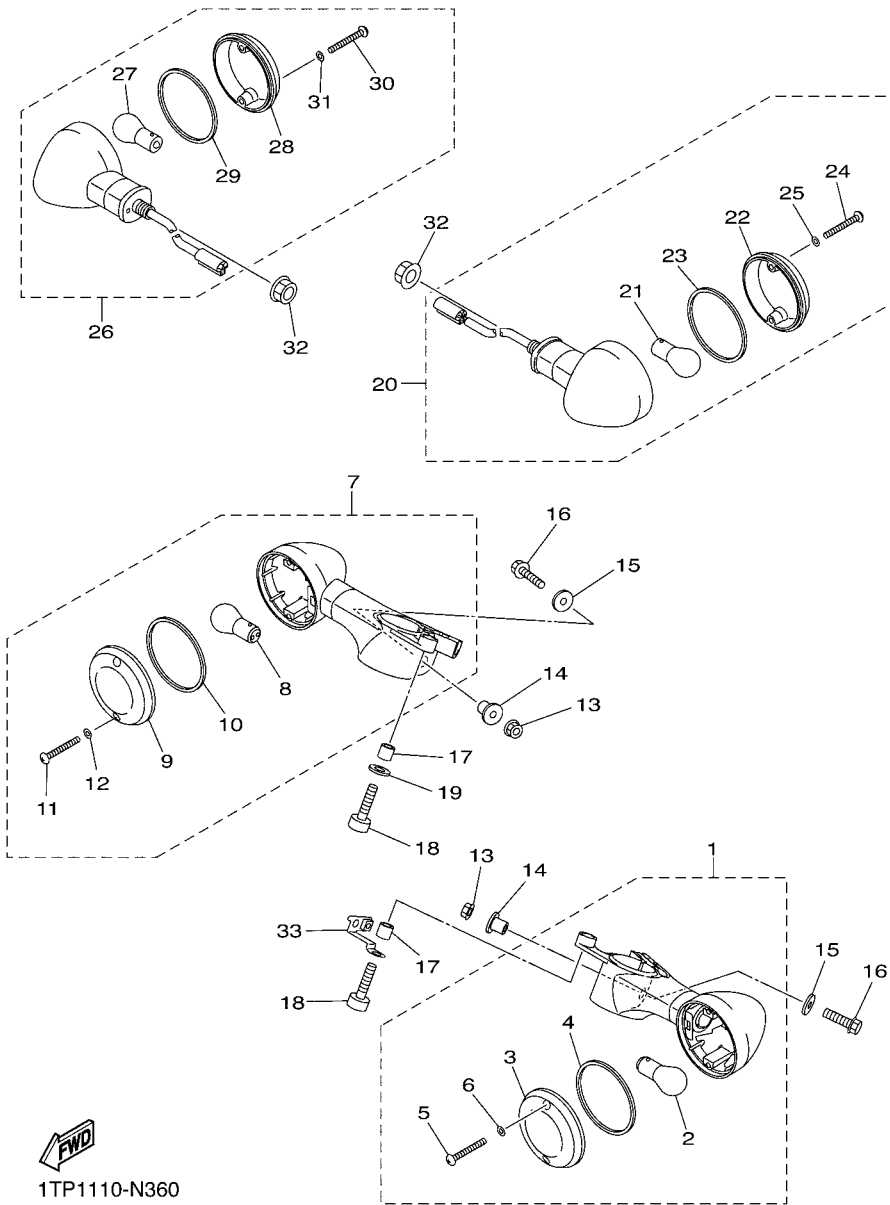

1TP1110-N360

FIG. 38 HEADLIGHT

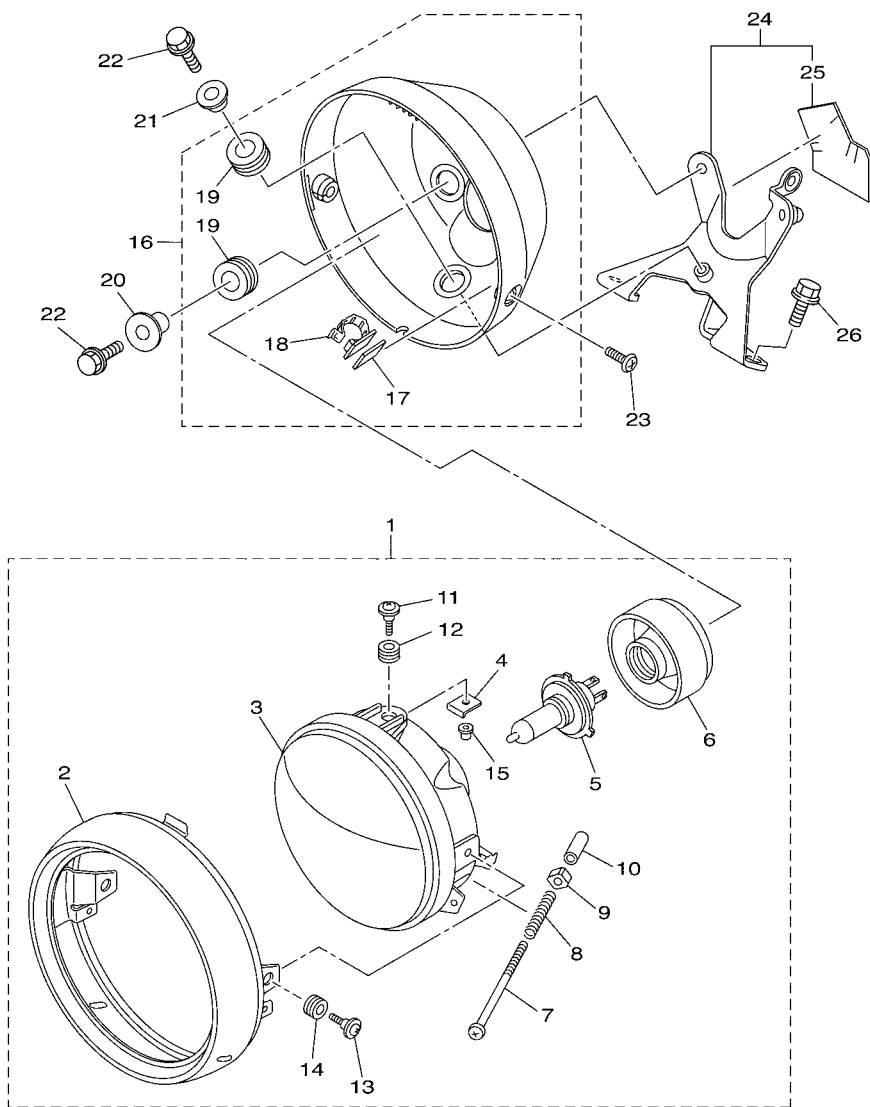

1TP1110-N380

REF. NO.	PART NO.	DESCRIPTION	1TP1	1TP2		REMARKS
1	5S7-84310-00	HEADLIGHT UNIT ASSY	1	1		
2	5S7-84315-00	.RIM, HEADLIGHT	1	1		
3	5PX-84320-00	.LENS ASSY	1	1		
4	5PX-84318-00	.STAY, HEADLIGHT 1	1	1		
5	8G9-84314-00	.BULB (12V-60/55W)	1	1		(H4)HALOGEN
6	5PX-84397-00	.COVER, SOCKET	1	1		
7	5PX-84331-00	.SCREW, RIM ADJUSTING	2	2		
8	5PX-84332-00	.SPRING, SCREW	2	2		
9	5PX-84334-00	.NUT, ADJUSTING	2	2		
10	5PX-84385-00	.CAP,1	2	2		
11	5PX-84325-00	.SCREW, RIM FITTING	2	2		
12	5PX-84354-00	.GROMMET	2	2		
13	5PX-84125-00	.SCREW, RIM FITTING	2	2		
14	5PX-84352-00	.GROMMET	2	2		
15	5PX-84317-00	.NUT	4	4		
16	1TP-84330-00	BODY ASSY	1	1		
17	1TP-28428-00	.SEAL 1	1	1		
18	90464-09009	.CLAMP	1	1		
19	4WM-84366-00	.DAMPER, HEADLIGHT 1	3	3		
20	90387-067K8	COLLAR	2	2		
21	90387-06040	COLLAR	1	1		
22	95022-06020	BOLT, FLANGE	3	3		
23	98907-05014	SCREW, BIND	2	2		
24	1TP-8411A-00	HEAD LIGHT STAY ASSY.	1	1		
25	1TP-84136-00	.DAMPER, HEADLIGHT STAY	1	1		
26	95027-08035	BOLT, FLANGE	2	2		

FIG. 39 TAILLIGHT

REF. NO.	PART NO.	DESCRIPTION	TTP1	TTP2	REMARKS
1	1TP-84700-00	TAILLIGHT ASSY	1	1	
2	1TP-84736-00	DAMPER, TAIL 1	1	1	
3	90387-06161	COLLAR	2	2	
4	95302-06600	NUT	2	2	
5	5S7-84751-01	BRACKET, LICENSE	1	1	
6	95602-06100	NUT, U	2	2	
7	95022-06014	BOLT, FLANGE	2	2	
8	90201-06380	WASHER PLAIN	2	2	
9	449-85131-02	REFLECTOR, REAR 1	2	2	
10	95602-05200	NUT, SELF-LOCKING	2	2	
11	1TP-84740-00	LICENCE LIGHT ASSY	1	1	
12	1TP-84547-00	.CORD, LICENCE LIGHT	1	1	
13	1TP-84347-00	.BULB	1	1	
14	90387-05003	COLLAR	2	2	
15	90480-11008	GROMMET	2	2	
16	90201-054K4	WASHER, PLATE	2	2	
17	3Y6-85130-02	REAR REFLECTOR ASSY	1	1	
18	95702-05500	NUT, FLANGE	3	3	
19	1TP-84717-00	CORD, TAILLIGHT	1	1	

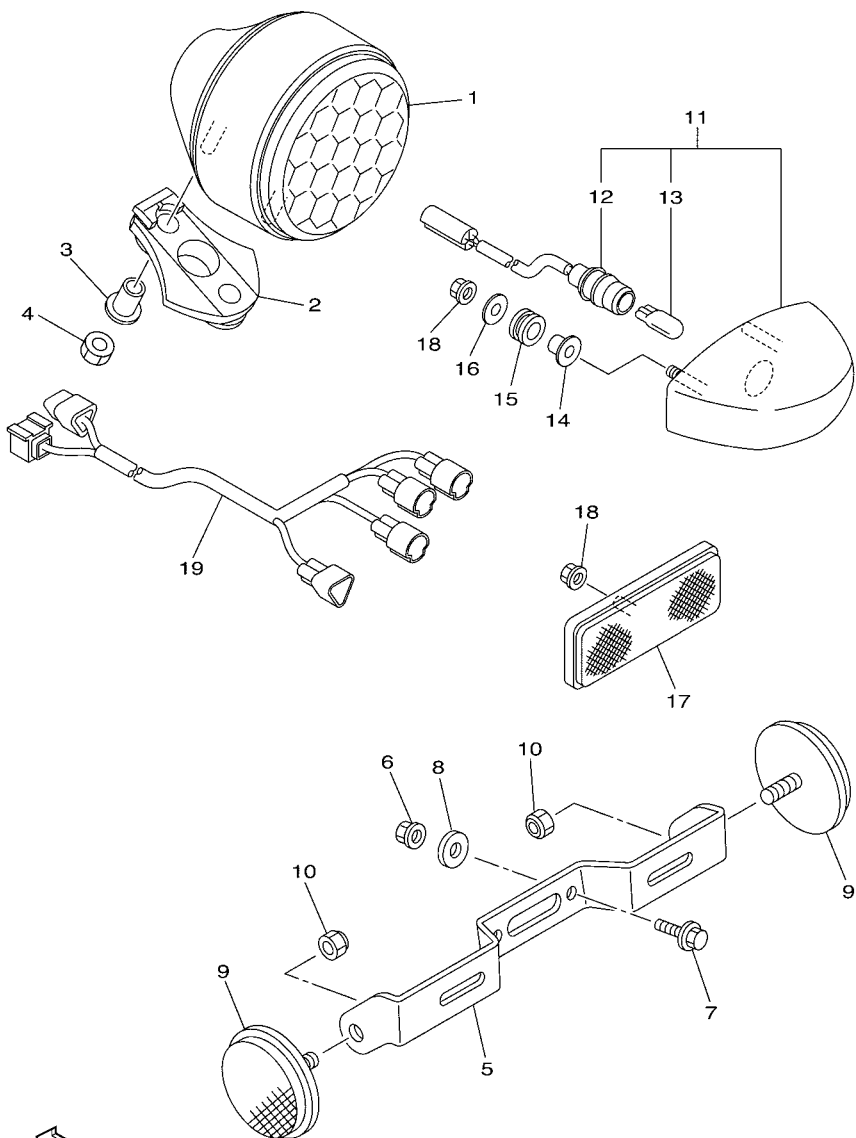

1TP1110-N390

FIG. 40 HANDLE SWITCH & LEVER

REF. NO.	PART NO.	DESCRIPTION	1TP1	1TP2			REMARKS
1	5BN-83912-20	LEVER 1	1	1			
2	5BN-82911-20	HOLDER, LEVER 1	1	1			
3	4TR-83913-00	COLLAR, LEVER 1	1	1			
4	4TR-83945-10	BOLT, LEVER	1	1			
5	90123-08083	BOLT	1	1			
6	90179-08316	NUT	1	1			
7	97007-06020	BOLT	1	1			
8	95607-06100	NUT, U	1	1			
9	3YX-82917-01	SWITCH	1	1			
10	98702-03020	SCREW, FLAT HEAD	1	1			
11	5VS-2589F-00	BOLT, LEVER	1	1			
12	95602-06100	NUT, U	1	1			
13	3D8-83922-10	LEVER 2	1	1			
14	36Y-82917-00	SWITCH	1	1			
15	98502-04014	SCREW, PAN HEAD	1	1			
16	92902-04600	WASHER, PLATE	1	1			
17	1TP-83973-00	SWITCH, HANDLE 3	1	1			
18	98507-05030	.SCREW, PAN HEAD	2	2			
19	90464-13073	CLAMP	2	2			
20	1TP-83972-00	SWITCH, HANDLE 4	1	1			
21	98507-05030	.SCREW, PAN HEAD	2	2			
22	90464-13073	CLAMP	2	2			

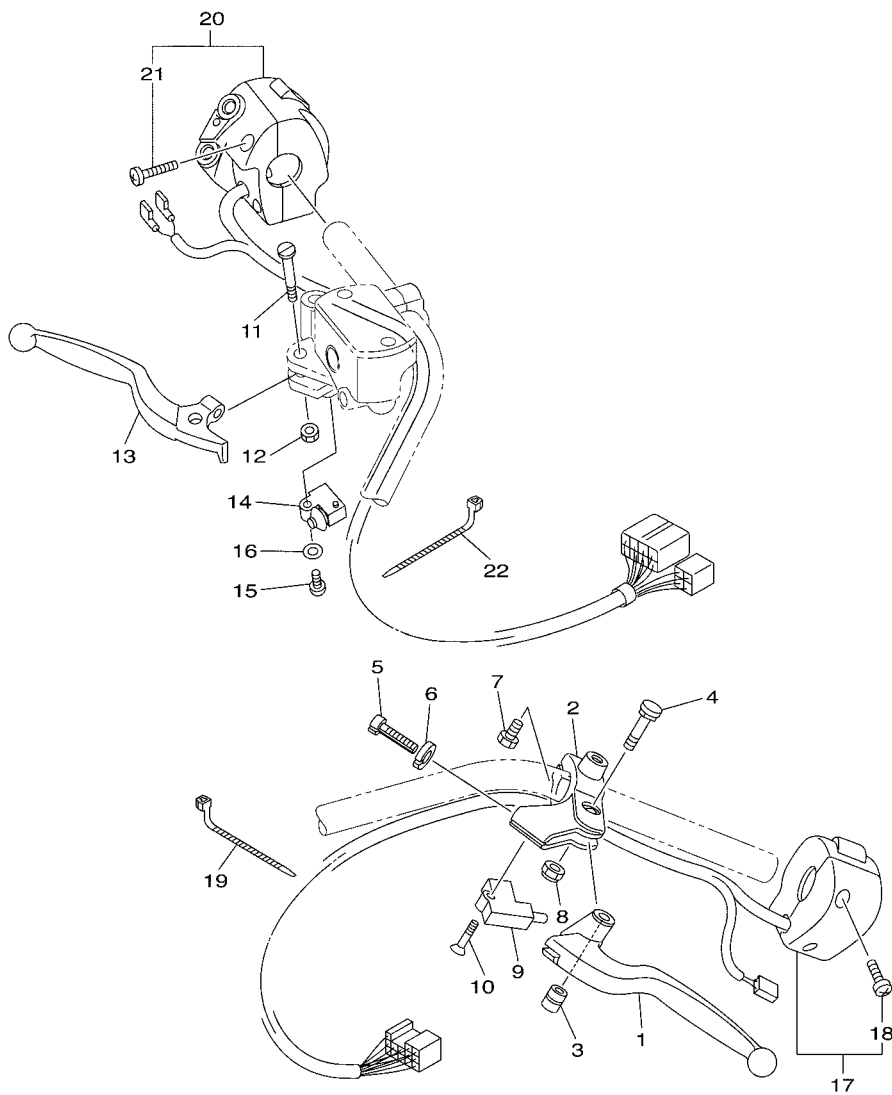

1TP1110-N400

FIG. 41 ELECTRICAL 1

REF. NO.	PART NO.	DESCRIPTION	TTP1	TTP2	REMARKS
1	5S7-85720-00	OIL LEVEL GAUGE ASSY	1	1	
2	5VY-8A8E0-00	.O-RING	1	1	
3	95022-06016	BOLT, FLANGE	2	2	
4	1TP-82566-00	SWITCH, SIDE STAND	1	1	
5	91317-05016	BOLT	2	2	
6	1TP-82530-00	STOP SWITCH ASSY	1	1	
7	3GB-82540-01	NEUTRAL SWITCH ASSY	1	1	
8	5S7-82509-10	WIRE, SUB LEAD	1	1	
9	90464-13077	CLAMP	2	2	
10	90430-10148	GASKET	1	1	
11	3D8-21359-01	BRACKET, COIL	1	1	
12	1TP-82310-00	IGNITION COIL ASSY	1	1	
13	1S4-82310-00	IGNITION COIL ASSY	1	1	
14	90110-06175	BOLT, HEXAGON SOCKET HEAD	4	4	
15	5S7-82370-00	PLUG CAP ASSY	2	2	
16	90445-14020	HOSE (L65)	1	1	
17	91312-06008	BOLT	2	2	
18	90464-09129	CLAMP	1	1	
19	90464-09008	CLAMP	1	1	
20	1TP-8591A-00	ENGINE CONTROL UNIT ASSY	1	1	
21	1TP-83755-00	SENSOR, SPEED	1	1	
22	4D9-81168-00	.O-RING	1	1	
23	90110-06168	BOLT, HEXAGON SOCKET HEAD	1	1	
24	1TP-81948-00	BRACKET	1	1	
25	99530-08012	PIN, DOWEL	2	2	
26	90110-06300	BOLT, HEXAGON SOCKET HEAD	2	2	
27	4P9-83591-00	THERMO UNIT	1	1	

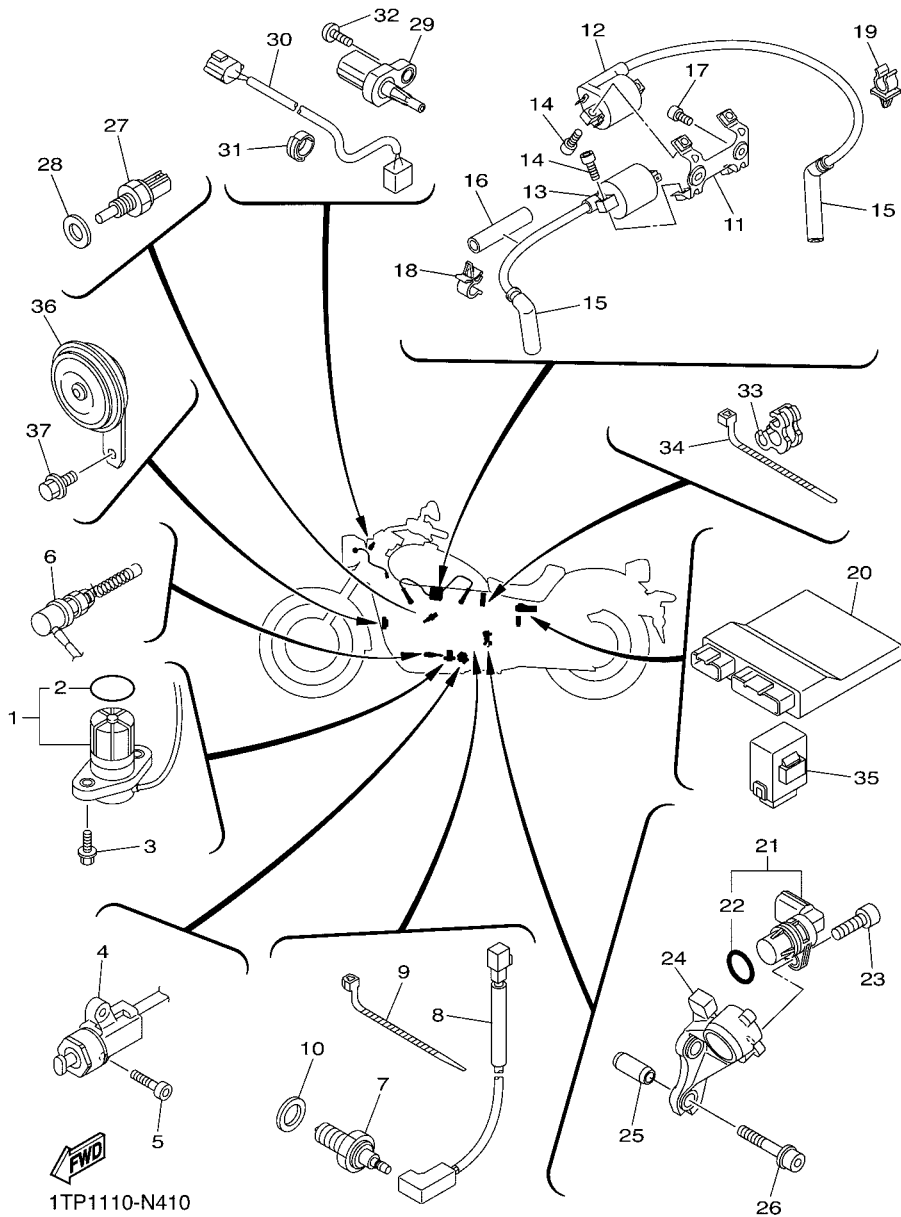
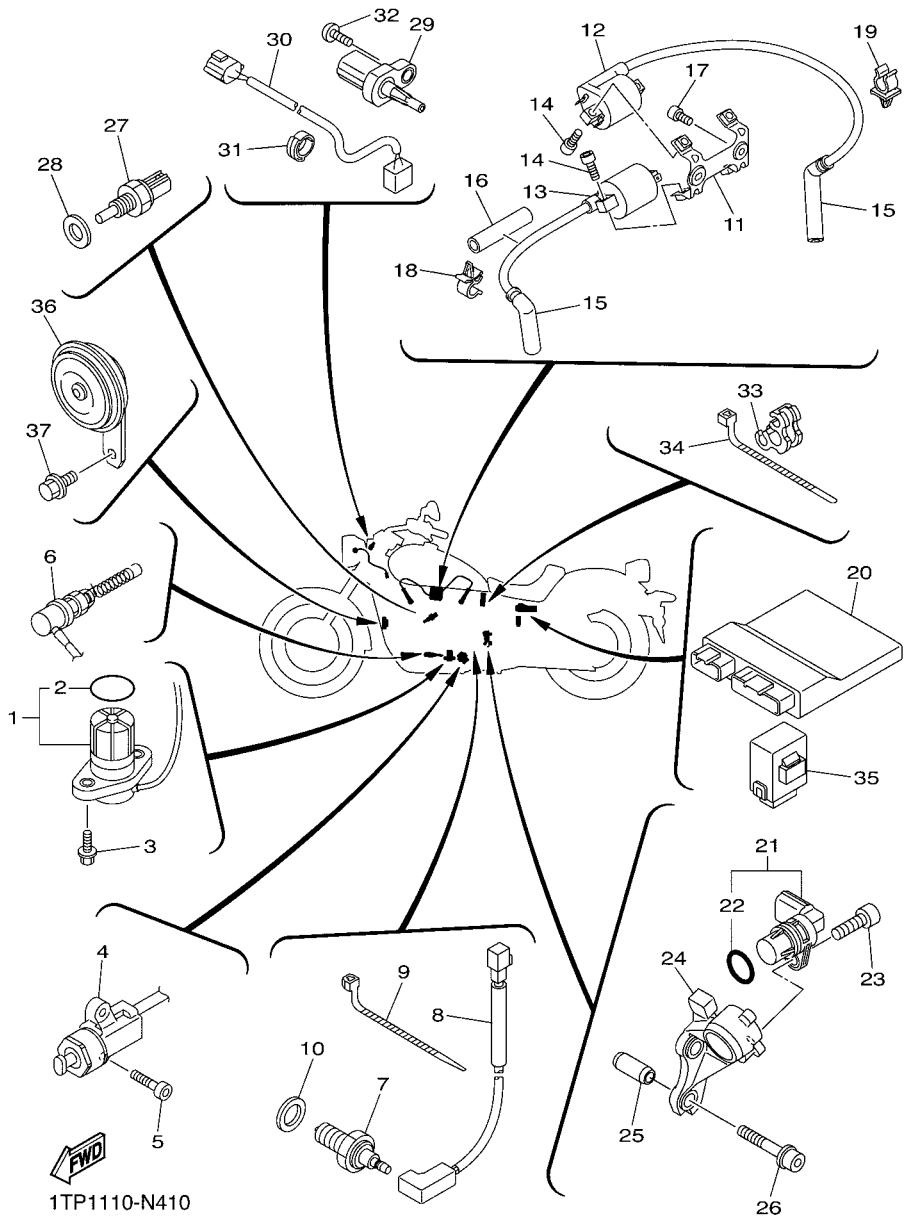

FIG. 41 ELECTRICAL 1

REF. NO.	PART NO.	DESCRIPTION	1TP1	1TP2	REMARKS
28	90201-10128	WASHER, PLATE	1	1	
29	5YU-85886-00	SENSOR, AIR TEMPERATURE	1	1	
30	1TP-82509-00	WIRE, SUB LEAD	1	1	
31	90464-13227	CLAMP	1	1	
32	98502-05012	SCREW, PAN HEAD	1	1	
33	1TP-81443-00	CLAMP, LEAD 1	1	1	
34	90464-20258	CLAMP	1	1	
35	5S7-83350-00	FLASHER RELAY ASSY	1	1	
36	2S3-83371-00	HORN	1	1	
37	90105-082A5	BOLT, FLANGE	1	1	



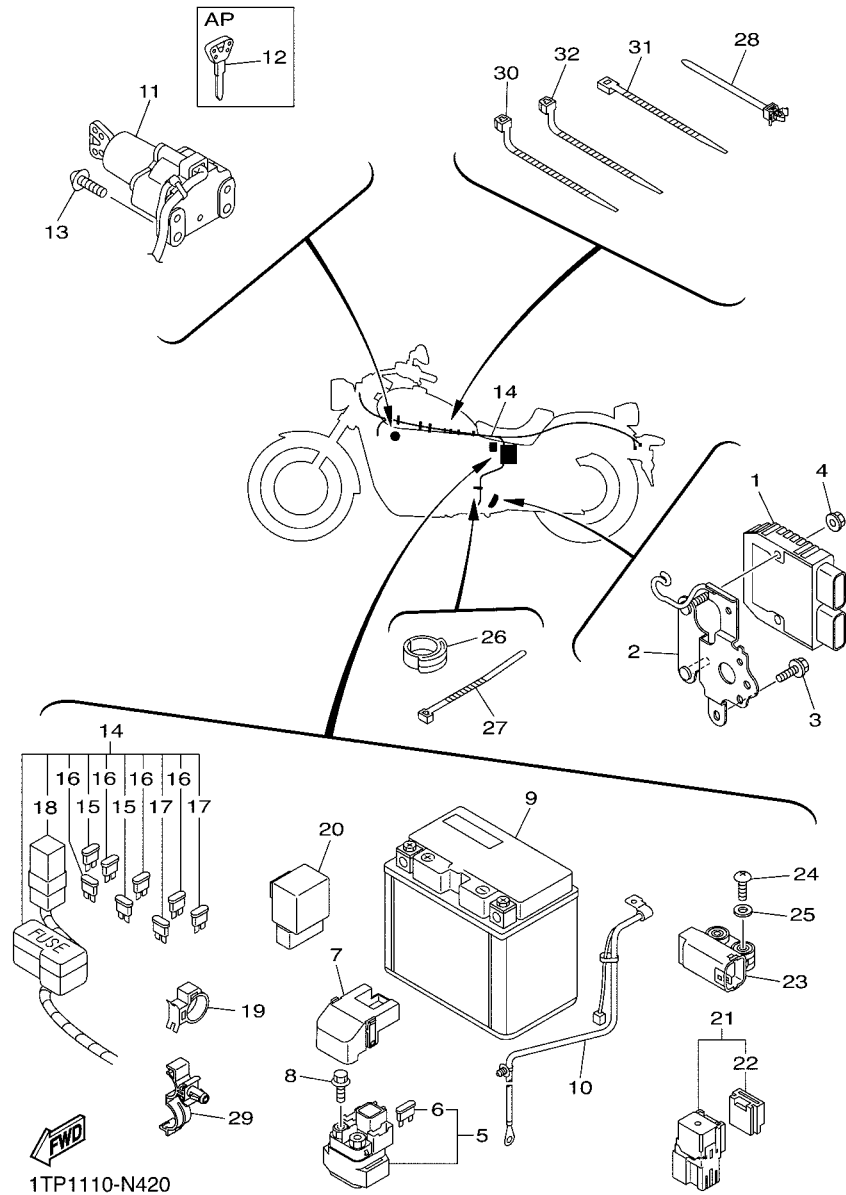

FIG. 42 ELECTRICAL 2

REF. NO.	PART NO.	DESCRIPTION	TTP1	TTP2	REMARKS
1	1D7-81960-01	RECTIFIER & REGULATOR ASSY	1	1	
2	1TP-2128A-00	BRACKET, REGULATOR	1	1	
3	95827-06012	BOLT, FLANGE	2	2	
4	95707-06500	NUT, FLANGE	2	2	
5	5S7-81940-00	STARTER RELAY ASSY (RC19-089A)	1	1	
6	42X-82151-00	.FUSE (10A-BL)	2	2	
7	5SL-82119-10	COVER, LEAD WIRE	1	1	
8	95022-06008	BOLT, FLANGE	2	2	
9	2D1-82100-00	BATTERY ASSY(GS YUASA YTZ14S)	1	1	
10	1TP-82116-00	WIRE, MINUS LEAD	1	1	
11	1TP-82510-00	MAIN SWITCH ASSY	1	1	
12	4BH-82511-09	BLANK KEY	1	1	AP
13	90149-06188	SCREW	2	2	
14	1TP-82590-00	WIRE HARNESS ASSY	1	1	
15	5JJ-82151-10	.FUSE (15A-BL)	2	2	
16	5JJ-82151-00	.FUSE (7.5A-BL)	4	4	
17	5JJ-82151-20	.FUSE (20A-BL)	2	2	
18	5PS-82151-00	.FUSE (40A)	1	1	
19	90464-15192	CLAMP	1	1	
20	5VK-81950-30	RELAY ASSY (5VK-30)	1	1	
21	1TP-81950-00	RELAY ASSY (1TP-00)	1	1	
22	5EA-81952-00	.HOLDER, RELAY	1	1	
23	5VU-82576-01	SENSOR, LEAN ANGLE	1	1	
24	90160-04009	SCREW, ROUND TAPPING	2	2	
25	90201-04030	WASHER, PLATE	2	2	
26	90464-13227	CLAMP	1	1	
27	90464-36005	CLAMP	1	1	

NUMERICAL INDEX

PART NO.	REF. NO.	PART NO.	REF. NO.	PART NO.	REF. NO.	PART NO.	REF. NO.	PART NO.	REF. NO.	PART NO.	REF. NO.
5S7-11101-18	1 - 1	5S7-12180-10	5 - 2	1TP-1465T-00	10 - 2	3D8-16181-10	14 - 3	1TP-2122C-00	18 - 3	1TP-2311H-00	23 - 37
5S7-11101-38	1 - 6	31G-12210-01	5 - 11	1TP-1465U-00	10 - 3	4WM-16193-00	14 - 2	1TP-2124E-00	20 - 29	4KM-23123-01	22 - 1
1TP-1111F-00	1 - 28	3GD-12213-00	5 - 14	1TP-1468W-00	10 - 22	5JW-16321-10	14 - 10	1TP-21288-00	18 - 18	4FM-23125-40	23 - 6
5S7-1111F-00	1 - 39	31G-12214-00	5 - 12	1TP-14710-00	10 - 7	341-16321-20	14 - 9	1TP-2128A-00	42 - 2		23 - 24
1TP-1111M-00	1 - 23	5S7-12214-00	2 - 3	1TP-14715-00	10 - 9	2H7-16325-00	14 - 11	1TP-21314-00	18 - 4	1TP-23126-00	23 - 2
1TP-1111N-00	1 - 24		2 - 7	1TP-14728-00	10 - 11	5S7-16334-00	14 - 14	1TP-21317-00	18 - 2	1TP-23136-00	23 - 20
1TP-1111P-00	1 - 33	5S7-12215-00	2 - 2	1TP-14738-00	10 - 12	36Y-16335-00	14 - 15	3D8-21359-01	41 - 11	1TP-23141-00	23 - 14
1TP-1111R-00	1 - 34		2 - 6	1TP-14748-00	10 - 13	5S7-16340-00	14 - 24	5S7-2139X-00	20 - 7		23 - 32
1TP-1112F-00	1 - 30	31G-12222-00	5 - 13	5YU-14755-00	10 - 10	132-16346-00	17 - 1	1TP-21510-00-P0	19 - 1	4EB-23144-00	23 - 10
4G0-11133-11	1 - 2	5S7-12231-00	5 - 8	1TP-14772-00	10 - 16	3D8-16350-00	14 - 12	1TP-21510-00-P1	19 - 1		23 - 28
	1 - 7	3D8-12241-00	5 - 9	1TP-14799-00	10 - 14	1TX-16352-00	14 - 16	1D6-2153E-00	19 - 25	4EB-23145-01	23 - 8
1TP-1113F-00	1 - 38	5S7-13171-00	6 - 10	1TP-14860-00	24 - 28	4XV-16356-01	14 - 18	1TP-21587-00	19 - 3		23 - 26
1TP-1114F-00	1 - 18	5S7-13300-00	6 - 1	5S7-15100-09	11 - 1	3D8-16371-00	14 - 8	1TP-21588-00	19 - 4	1TP-23146-00	23 - 7
1TP-11152-00	1 - 45	3D8-13354-10	14 - 28	1TP-15113-00	12 - 47	3D8-16382-00	12 - 30	1TP-21610-00-P0	19 - 9		23 - 25
1TP-11166-00	9 - 13	3D8-13355-00	6 - 2	2H7-15138-00	11 - 4	5S7-17121-00	15 - 11	1TP-21610-00-P1	19 - 9	1TP-23149-00	23 - 15
5S7-11181-00	1 - 12	3D8-13416-00	6 - 7	3D8-15154-00	11 - 2	5S7-17131-10	15 - 6	1TP-21613-00	19 - 18		23 - 33
5S7-11185-00	1 - 41	5GH-13440-50	7 - 4	5S7-15316-00	12 - 48	5S7-17141-10	15 - 8	1TP-21614-00	19 - 19	1TP-23156-00	23 - 9
5S7-11186-00	1 - 17	3D8-13490-00	7 - 1	3D8-15337-02	12 - 37	5S7-17151-00	15 - 3	1TP-2162R-00	19 - 12		23 - 27
5S7-11195-00	1 - 42	8FP-13556-00	8 - 4	3D8-15353-00	11 - 13	5S7-17211-00	15 - 26	1TP-21639-00	19 - 17	1TP-23158-00	23 - 12
5S7-11196-00	1 - 21	5S7-13586-00	8 - 10	3D8-15358-00	11 - 12	5S7-17221-00	15 - 16	1TP-21643-00	19 - 22		23 - 30
214-11198-01	6 - 15	1TP-13590-00	8 - 1	5S7-15362-10	12 - 9	5S7-17231-00	15 - 23	1TP-21668-00	21 - 14	1TP-23170-00	23 - 5
1TP-11311-00	2 - 1	1TP-13750-00	8 - 13	3D8-15368-00	11 - 15	5S7-17241-10	15 - 19	34B-21684-00	20 - 38		23 - 23
	2 - 5	1TP-13750-10	8 - 13	3D8-15381-00	15 - 29	5S7-17251-00	15 - 24	5RU-21686-00	20 - 37	4FM-23171-40	23 - 4
5S7-11351-00	2 - 9	5S7-13761-00	8 - 2	3D8-15388-00	12 - 15	5S7-17411-10	15 - 1	1TP-21688-00	19 - 16		23 - 22
5S7-11352-00	2 - 10	5S7-13769-00	8 - 9	5S7-15411-00	12 - 1	5S7-17421-00	15 - 14	55K-21708-00	20 - 20	1TP-23173-00	23 - 11
5S7-11411-00	3 - 1	1TP-13895-00	8 - 21	1TP-15415-00	12 - 33	5S7-17651-00	15 - 34	1TP-21711-00	20 - 19		23 - 29
5S7-11603-00	3 - 6	1TP-13906-00	8 - 8	3D8-1541A-01	12 - 36	3D8-18101-00	17 - 4	2N4-21717-00	20 - 24	1TP-23181-00	23 - 13
5S7-11631-01	3 - 5	1TP-13907-00	24 - 16	5S7-15421-01	12 - 14	1TP-18110-00	17 - 11	1TP-21721-00	20 - 25		23 - 31
5PS-11633-00	3 - 8	1TP-13915-00	24 - 23	1TP-15423-00	12 - 25	1TP-18112-00	17 - 16	1TP-2172E-00	20 - 5	1TP-23188-00	23 - 18
5S7-11650-00	3 - 2	1TP-13930-00	8 - 5	1TP-15426-01	12 - 40	5VN-18113-00	17 - 12	1TP-2172W-00	20 - 35		23 - 36
5YU-11654-00	3 - 3	3D8-14104-00	8 - 16	5S7-1542A-00	12 - 11		33 - 2	1TP-2176E-00	20 - 34	4PU-2331G-00	23 - 39
5YU-11656-10	3 - 4	8A7-14139-00	8 - 18	3D8-15441-00	12 - 35	1TP-18115-00	17 - 17	1TP-2177A-00	20 - 11	1TP-23340-00	23 - 38
5YU-11656-20	3 - 4	5PS-14147-00	8 - 3	3D8-15451-00	12 - 2	1D7-18127-00	17 - 3	1TP-2177G-00	20 - 1	1TP-23389-00	22 - 15
5YU-11656-30	3 - 4	1TP-14148-00	8 - 27	3D8-15461-00	12 - 18	3D8-18140-00	17 - 7	1TP-22110-00	21 - 1	1TP-23408-00	22 - 19
5S7-12111-00	4 - 1	895-14169-00	8 - 17	1TP-15470-00	12 - 46	3D8-18175-00	17 - 6	1TP-22141-00	21 - 2	1W1-23416-00	22 - 3
5S7-12113-00	4 - 3	1TP-14402-00	9 - 7	5S7-15484-00	34 - 3	3D8-18511-00	16 - 3	1TP-2219X-00	21 - 9	26H-23418-01	22 - 6
3YF-12116-00	4 - 4	1TP-14411-00	9 - 1	1TP-15492-00	12 - 12	3D8-18512-00	16 - 4	1TP-22210-00	21 - 15	1TP-23441-00	22 - 17
3YF-12117-01	4 - 6	1TP-14451-00	9 - 8	3D8-15512-01	13 - 8	3D8-18531-00	16 - 5	1TP-22311-00	21 - 10	1TP-23442-00	22 - 12
4G0-12118-00	4 - 7	1TP-14452-00	9 - 2	5S7-15512-01	13 - 5	3D8-18535-00	16 - 6	1TP-22312-00	21 - 12	3DM-23445-00	22 - 13
5H0-12119-00	4 - 5	3D8-14457-00	9 - 3	5S7-15515-00	13 - 1	5S7-18540-10	16 - 1	1TP-2256L-00	36 - 33	3FV-23462-00	23 - 41
5S7-12121-00	4 - 2	3D8-14462-00	9 - 4	1D7-15521-00	13 - 6	136-18542-00	16 - 2	1TP-23102-00	23 - 1	1TP-23484-00	22 - 22
5S7-12146-00	4 - 10	3D8-14467-00	8 - 19	4WM-15522-00	13 - 9	1TP-21110-00	18 - 1	1TP-23103-00	23 - 19	1TP-24136-00	24 - 39
5S7-12151-00	4 - 8	4XY-14568-00	24 - 35	5S7-15561-00	13 - 2	1TP-21149-00	18 - 21	1TP-23110-00	23 - 3	1TP-2413X-00	24 - 48
5S7-12156-00	4 - 11	1TP-14610-00	10 - 1	4NK-15590-00	13 - 3	1TP-2115C-00	18 - 16		23 - 21	1TP-2413Y-00	24 - 9
4X7-12159-00	4 - 12	3EG-14613-00	10 - 19	5S7-16111-00	14 - 1	1TP-2116F-00	18 - 5	1TP-23111-00	23 - 17	1TP-24141-00	24 - 6
5S7-12161-00	4 - 9	1TP-14615-00	10 - 20	1TP-16150-00	14 - 6	3D8-2117G-00	18 - 20		23 - 35	1TP-2414H-00	24 - 3
5S7-12170-10	5 - 1	1TP-14629-00	10 - 4	5YU-16154-00	14 - 7	1TP-21183-00	18 - 9	1TP-23118-00	23 - 16	1TP-2414J-00	24 - 4
5S7-12176-00	5 - 3	1TP-1465R-00	10 - 28	3D8-16164-10	14 - 19	1TP-2118K-00	24 - 55		23 - 34	1TP-2414K-00	24 - 5

NUMERICAL INDEX

PART NO.	REF. NO.	PART NO.	REF. NO.	PART NO.	REF. NO.	PART NO.	REF. NO.	PART NO.	REF. NO.	PART NO.	REF. NO.
1TP-2414N-00	24 - 19	1TP-2581T-00	27 - 1	1TP-27216-00	33 - 5	3TJ-82131-00	20 - 12	1TP-83559-00	37 - 7	3JB-W0047-00	27 - 5
5PX-24170-00	24 - 46	5GM-25824-00	29 - 10	4BP-27222-02	33 - 15	42X-82151-00	42 - 6	4P9-83591-00	41 - 27	5JW-W0047-00	29 - 5
5PX-24180-00	24 - 38	47X-25824-01	27 - 11	1TP-27243-00	33 - 3	5JJ-82151-00	42 - 16	1TP-83755-00	41 - 21	1D7-W0057-00	29 - 4
1TP-24181-00	24 - 8	1D7-25825-00	27 - 12	1TP-27262-00	33 - 6	5PS-82151-00	42 - 18	5BN-83912-20	40 - 1	3YX-W0057-00	27 - 4
4D3-24181-00	20 - 30		29 - 11	1TP-27311-00	32 - 9	5JJ-82151-10	42 - 15	4TR-83913-00	40 - 3	1TP-Y2343-00	22 - 9
1TP-24182-00	24 - 10	4DN-25827-00	27 - 13	1TP-27315-00	32 - 12	5JJ-82151-20	42 - 17	3D8-83922-10	40 - 13	1TP-Y2410-00-01	24 - 1
1TP-24183-00	24 - 12	5GJ-25827-00	29 - 13	1TP-27322-00	32 - 13	1S4-82310-00	41 - 13	4TR-83945-10	40 - 4	1TP-YK241-00-P1	24 - 1
1TP-24244-00	24 - 2	4BP-2582A-00	33 - 13	1TP-27411-00	32 - 1	1TP-82310-00	41 - 12	1TP-83972-00	40 - 20	90101-08777	28 - 23
1TP-24313-00	24 - 33	1TP-2582W-00	29 - 1	4VR-27413-00	32 - 3	5S7-82370-00	41 - 15	1TP-83973-00	40 - 17	90101-10016	5 - 5
1TP-24314-00	24 - 30	1TP-2583V-00	33 - 11		32 - 20	5S7-82380-00	8 - 24	1TP-8411A-00	38 - 24	90105-06066	6 - 3
1TP-24315-00	24 - 26	4B5-25852-00	31 - 3	1TP-27421-00	32 - 18	1TP-82509-00	41 - 30	5PX-84125-00	38 - 13	90105-06136	37 - 6
1TP-24316-00	24 - 36	2KF-25852-50	33 - 28	1TP-27451-00	32 - 2	5S7-82509-10	41 - 8	1TP-84136-00	38 - 25	90105-06144	11 - 10
1TP-24330-00	24 - 21	4B5-25854-00	31 - 5	1TP-27461-00	32 - 19	1TP-82510-00	42 - 11	5S7-84310-00	38 - 1	90105-08126	25 - 7
1TP-24364-00	1 - 46	360-25854-01	33 - 26	3D8-28100-10	20 - 40	4BH-82511-09	42 - 12	8G9-84314-00	38 - 5	90105-08251	10 - 25
1TP-24398-00	24 - 24	2GU-25855-00	33 - 27	1TP-28110-00	20 - 42	1TP-82530-00	41 - 6	5S7-84315-00	38 - 2	90105-082A5	41 - 37
4KM-24453-00	8 - 15	4B5-25855-00	31 - 4	1TP-28170-00	20 - 16	3GB-82540-01	41 - 7	5PX-84317-00	38 - 15	90105-10364	32 - 26
1TP-24474-00	24 - 18	4BP-2585F-01	33 - 14	1TP-28173-00	20 - 39	1TP-82566-00	41 - 4	5PX-84318-00	38 - 4	90105-10415	18 - 12
1TP-24486-00	24 - 17	3D8-25867-00	31 - 8	14B-2836B-00	22 - 10	5VU-82576-01	42 - 23	5PX-84320-00	38 - 3	90105-10424	32 - 28
4NK-24602-20	24 - 7	1TP-25872-00	31 - 9	1TP-28428-00	38 - 17	1TP-82590-00	42 - 14	5PX-84325-00	38 - 11	90105-10426	32 - 10
1TP-24710-00	25 - 1	1TP-2587A-00	33 - 23	1TP-46241-00	28 - 21	5BN-82911-20	40 - 2	1TP-84330-00	38 - 16	90105-10428	18 - 14
1TP-24718-00	25 - 4	1TP-25886-00	31 - 12	4D9-81168-00	41 - 22	36Y-82917-00	40 - 14	5PX-84331-00	38 - 7	90105-10434	18 - 6
509-24724-00	25 - 2	27D-25887-00	19 - 5	1TP-81410-00	34 - 1	3YX-82917-01	40 - 9	5PX-84332-00	38 - 8	90105-10638	27 - 14
22W-24741-00	25 - 3	4NK-25888-00	33 - 30	1TP-81443-00	41 - 33	1TP-83310-00	36 - 1	5PX-84334-00	38 - 9	90105-12086	18 - 15
1TP-2475N-00	25 - 6	1TP-2588F-00	33 - 21	5S7-81450-10	34 - 2	5VN-83311-00	36 - 2	1TP-84347-00	39 - 13	90105-12088	18 - 11
1TP-2486A-00	24 - 44	31A-25894-10	33 - 25	1TP-81815-00	35 - 9		36 - 8	5PX-84352-00	38 - 14	90105-12090	18 - 8
1TP-25168-00	26 - 1	1TP-25895-00	33 - 32	28P-81826-00	35 - 6	5PX-83312-10	36 - 3	5PX-84354-00	38 - 12	90105-12091	18 - 13
3MA-25181-10	26 - 9	5VS-2589F-00	40 - 11	4XV-8182A-00	35 - 8		36 - 9	4WM-84366-00	38 - 19	90105-12584	13 - 13
1TP-25317-00	28 - 4	5VS-2589H-00	31 - 6		35 - 11	5PX-83313-00	36 - 4	5PX-84385-00	38 - 10	90109-06015	2 - 4
1TP-25338-00	28 - 1	3P6-25914-00	29 - 6	4B5-81840-00	35 - 2		36 - 10	5PX-84397-00	38 - 6		2 - 8
4WM-25364-00	28 - 5	5JW-25914-10	27 - 6	35C-81844-00	35 - 5		36 - 23	1TP-84547-00	39 - 12	90109-08195	22 - 20
1TP-25366-00	28 - 10	1D7-25919-00	29 - 9	1TP-81845-00	12 - 22		36 - 29	1TP-84700-00	39 - 1	90109-083G4	27 - 2
4WM-25376-10	28 - 16	4BP-25919-00	27 - 9	1FK-81847-00	35 - 4	1TP-83320-00	36 - 7	1TP-84717-00	39 - 19		29 - 2
1TP-25381-00	28 - 27	3YX-25929-00	27 - 10	3TB-81847-00	35 - 3	5C7-83330-10	36 - 20	1TP-84736-00	39 - 2	90110-06064	1 - 19
1TP-25383-00	28 - 6	4TT-25937-00	27 - 7		35 - 7	5VN-83331-00	36 - 21	1TP-84740-00	39 - 11	90110-06086	12 - 3
1TP-25388-00	28 - 22		29 - 7	4B5-81871-00	35 - 10		36 - 27	5S7-84751-01	39 - 5		12 - 19
5MT-25398-00	26 - 7	5GM-25975-00	29 - 12	1TP-81890-00	35 - 1	5C7-83340-10	36 - 26	11H-85110-01	19 - 7	90110-06161	6 - 9
	28 - 9	1TP-26111-00	30 - 1	5S7-81940-00	42 - 5	5PX-83342-10	36 - 22	3Y6-85130-02	39 - 17		6 - 13
5MT-25398-10	26 - 7	1TP-26240-00	30 - 3	1TP-81948-00	41 - 24		36 - 28	449-85131-02	39 - 9		11 - 14
	28 - 9	1TP-26241-00	30 - 2	1TP-81950-00	42 - 21	5PX-83348-00	36 - 6	5S7-85720-00	41 - 1		11 - 16
5MT-25398-20	26 - 7	1TP-26280-00	30 - 10	5VK-81950-30	42 - 20		36 - 12	1TP-85752-00	24 - 51		34 - 4
	28 - 9	1D7-26290-00	30 - 11	5EA-81952-00	42 - 22		36 - 25	42X-85753-00	24 - 52	90110-06168	8 - 7
1TP-25470-00	28 - 18	1TP-26311-00	30 - 4	1D7-81960-01	42 - 1		36 - 31	8GL-85885-00	8 - 14		41 - 23
1TP-25807-00	31 - 2	1TP-26312-00	30 - 6	2D1-82100-00	42 - 9	5S7-83350-00	41 - 35	5YU-85886-00	41 - 29	90110-06175	41 - 14
1TP-25808-00	33 - 12	5VS-26332-00	31 - 7	1TP-82116-00	42 - 10	1TP-8336V-00	37 - 8	1TP-8591A-00	41 - 20	90110-06177	34 - 5
1TP-2580A-00	31 - 1	1TP-26335-00	30 - 8	5SL-82119-10	42 - 7	2S3-83371-00	41 - 36	5D1-8592A-00	10 - 18	90110-06182	12 - 16
27D-2580T-00	27 - 3	1TP-26475-00	18 - 23	18G-82131-00	20 - 14	1TP-83500-00	37 - 1	5YV-8A8E0-00	41 - 2	90110-06270	11 - 17
1TP-2580W-00	29 - 3	1TP-26481-00	18 - 25		20 - 17	1TP-83513-00	37 - 2	5S7-W0045-00	27 - 8	90110-06274	1 - 43
1TP-2581J-00	33 - 20	1TP-27200-00	33 - 1	1TP-82131-00	20 - 13	1TP-83519-00	37 - 5	1D7-W0046-00	29 - 8	90110-06300	41 - 26

NUMERICAL INDEX

PART NO.	REF. NO.	PART NO.	REF. NO.	PART NO.	REF. NO.	PART NO.	REF. NO.	PART NO.	REF. NO.	PART NO.	REF. NO.
90110-06311	12 - 20	90183-060A6	20 - 4	90269-05005	24 - 40	90430-10005	33 - 19	90480-10627	1 - 31	92902-04600	40 - 16
90110-06334	12 - 21		20 - 27	90269-06008	20 - 36	90430-10148	41 - 10	90480-11008	39 - 15	92902-05600	8 - 26
90110-08065	1 - 16	90185-10008	18 - 7	90269-07077	20 - 15	90430-10171	11 - 7	90480-13016	19 - 11	92902-08600	12 - 31
90110-08067	13 - 4		32 - 11	90280-05048	13 - 11	90445-11730	24 - 41	90480-13018	12 - 41	93101-14102	12 - 17
90110-10030	11 - 11		32 - 27	90338-07010	19 - 26	90445-14020	41 - 16	90480-13022	1 - 25	93102-12106	12 - 45
90110-10038	10 - 27	90185-12002	18 - 10	90340-14117	12 - 7	90445-16641	32 - 17		1 - 35	93102-15212	12 - 29
90110-10042	10 - 26	90185-18009	28 - 28	90340-14132	6 - 14	90450-54006	8 - 12	90480-13398	20 - 23	93102-28022	26 - 3
90111-05024	9 - 10	90201-04030	42 - 25	90340-36078	12 - 5	90464-06214	30 - 7	90480-14003	20 - 32	93102-45012	15 - 33
90111-06028	33 - 31	90201-05033	37 - 3	90387-05003	39 - 14	90464-09008	41 - 19	90480-14023	9 - 5	93106-28023	28 - 3
90111-06030	20 - 31	90201-054K4	39 - 16	90387-0602X	20 - 33	90464-09009	38 - 18	90480-20001	20 - 18	93106-30004	28 - 15
90111-06038	20 - 28	90201-06045	36 - 15	90387-06040	38 - 21	90464-09129	41 - 18	90480-24186	20 - 22	93108-44001	21 - 4
90111-06085	18 - 22	90201-06062	9 - 12	90387-06048	21 - 13	90464-12015	24 - 43	90506-18015	17 - 2	93109-28001	21 - 8
90111-06127	21 - 11	90201-062P7	20 - 10	90387-06072	33 - 29	90464-13073	40 - 19	90506-23015	32 - 15	93210-06564	6 - 12
90111-06130	1 - 27	90201-06380	39 - 8	90387-06076	36 - 14		40 - 22	90506-29006	32 - 16	93210-07135	12 - 24
	1 - 37	90201-08066	19 - 24	90387-06161	39 - 3	90464-13077	41 - 9	90508-18040	14 - 25	93210-09165	6 - 11
	12 - 43	90201-08083	33 - 9	90387-06173	20 - 26	90464-13227	41 - 31	90508-18054	32 - 6	93210-10096	7 - 2
90111-06147	10 - 29	90201-08119	21 - 18	90387-06177	24 - 13		42 - 26		32 - 23	93210-14003	6 - 8
90111-06148	10 - 5	90201-083P5	36 - 19	90387-06207	1 - 26	90464-14001	24 - 11	90508-32040	17 - 5	93210-14369	12 - 8
	10 - 15	90201-10029	14 - 26		1 - 36	90464-14006	42 - 28	90520-08003	20 - 41	93210-18319	11 - 3
90111-08005	19 - 20	90201-10074	21 - 16	90387-06239	20 - 3	90464-15192	42 - 19	91312-05010	8 - 6	93210-27370	12 - 10
90111-08081	19 - 23	90201-10128	41 - 28	90387-06267	20 - 8	90464-15195	42 - 30	91312-05016	24 - 20	93210-27672	15 - 31
90111-10006	10 - 17	90201-10591	5 - 6	90387-06286	12 - 42		42 - 32	91312-05025	9 - 9	93210-357A3	12 - 6
	19 - 21	90201-12008	13 - 12	90387-063E6	9 - 6	90464-16012	42 - 29	91312-06008	41 - 17	93306-00006	13 - 7
90116-12011	11 - 9	90201-12025	1 - 14	90387-067K8	38 - 20	90464-16240	24 - 22	91312-06016	1 - 20	93306-00304	14 - 13
90116-12012	11 - 8	90201-12045	28 - 20	90387-07717	19 - 15	90464-17003	30 - 9	91312-06020	8 - 11	93306-20417	28 - 2
90119-06173	5 - 10	90201-12688	17 - 13	90387-08085	36 - 17	90464-17009	24 - 32		8 - 20	93306-30317	26 - 2
90123-08083	40 - 5	90201-127E1	17 - 10	90387-087K5	32 - 7	90464-20258	41 - 34		17 - 20	93306-30437	28 - 12
90149-06108	24 - 54	90201-14220	22 - 14		32 - 24	90464-23239	33 - 34	91312-06025	9 - 11	93306-30610	15 - 28
90149-06188	42 - 13	90201-177G4	17 - 8	90387-10020	32 - 14	90464-32060	42 - 31	91312-08016	1 - 44	93306-37215	15 - 13
90149-08054	21 - 19	90201-18020	28 - 29	90387-16030	21 - 3	90464-36005	42 - 27	91312-08035	12 - 38	93306-37817	15 - 12
90149-08055	22 - 21	90201-220T0	22 - 8	90387-16032	21 - 7	90465-06017	10 - 6	91314-06025	5 - 15	93310-33560	14 - 21
90151-06024	15 - 30	90201-224L4	15 - 27	90387-172A5	26 - 4	90467-07093	8 - 22	91314-06030	35 - 12	93311-32698	28 - 11
90160-04009	42 - 24	90201-350F3	13 - 10	90387-173R6	26 - 8	90467-08092	8 - 23	91314-08025	22 - 18	93315-31502	12 - 28
90170-06024	17 - 18	90202-05193	24 - 53	90387-20034	28 - 25	90467-09037	8 - 28	91314-08030	22 - 11	93317-11096	12 - 27
90170-08010	33 - 16	90202-26142	22 - 5	90387-202U8	28 - 26	90467-09103	8 - 29	91314-08040	10 - 8	93317-11287	12 - 44
90170-08173	4 - 13	90206-12074	17 - 15	90387-25008	15 - 25		24 - 34	91314-10020	23 - 40	93317-52897	21 - 6
90170-18008	14 - 5	90208-20001	14 - 22	90387-25025	15 - 7		24 - 37	91317-05016	41 - 5	93399-99931	22 - 2
90170-22187	20 - 21	90208-22004	15 - 35	90387-26006	14 - 20		24 - 42	91317-06008	18 - 17	93399-99932	23 - 42
90176-08006	10 - 24	90209-25011	15 - 4	90387-28003	15 - 2		24 - 45	91317-08025	36 - 18	93440-10085	1 - 3
90176-08012	10 - 21	90209-28008	15 - 17	90387-28004	15 - 22		24 - 50	91401-20012	33 - 10		1 - 8
90176-10073	21 - 17	90214-25003	15 - 10	90387-30010	15 - 32	90467-12003	24 - 25	91401-25015	32 - 8	93440-28184	15 - 5
90176-12052	22 - 16	90214-25004	15 - 9	90387-31003	15 - 15		24 - 27		32 - 25	93440-31187	15 - 18
90176-22002	22 - 7	90214-28002	15 - 21	90401-10020	31 - 10	90467-14057	33 - 33	91815-16017	1 - 15	93450-22146	3 - 7
90179-08316	40 - 6	90214-29002	15 - 20		33 - 18	90467-150A6	24 - 29	92012-08012	24 - 15	93450-35163	28 - 14
90179-12004	1 - 13	90215-18003	14 - 4	90401-20008	7 - 3		24 - 31	92014-06014	12 - 13	93604-12037	5 - 4
90179-20007	14 - 23	90240-08124	33 - 8	90430-08119	1 - 5	90467-16195	9 - 14		12 - 26	93900-00030	26 - 6
90179-22028	15 - 36	90240-08145	32 - 5		1 - 10	90480-01015	19 - 10		12 - 34		28 - 8
90179-25004	22 - 4		32 - 22	90430-10005	31 - 11	90480-07003	20 - 2	92017-06012	20 - 6	94110-19025	26 - 5

NUMERICAL INDEX

PART NO.	REF. NO.	PART NO.	REF. NO.	PART NO.	REF. NO.	PART NO.	REF. NO.	PART NO.	REF. NO.	PART NO.	REF. NO.
94115-16025	28 - 7	95822-06014	19 - 13								
94580-25062	6 - 6	95822-08020	1 - 29								
94591-59132	5 - 7		1 - 32								
94701-00420	1 - 22	95827-06012	24 - 49								
95022-06008	42 - 8		42 - 3								
95022-06012	1 - 40	95880-06010	10 - 23								
95022-06014	20 - 9	97002-05020	8 - 25								
	39 - 7	97002-06020	33 - 7								
95022-06016	33 - 22	97002-06025	14 - 17								
	33 - 24	97007-06020	40 - 7								
	41 - 3	97702-40010	12 - 50								
95022-06020	38 - 22	97702-40014	12 - 49								
95022-08012	1 - 4	97704-40625	36 - 5								
	1 - 9		36 - 11								
95022-08014	25 - 5		36 - 24								
95022-10016	11 - 6		36 - 30								
95027-06010	18 - 19	97707-50016	37 - 4								
	19 - 6	98502-04014	40 - 15								
	31 - 13	98502-05012	41 - 32								
95027-06016	18 - 24	98507-05016	30 - 5								
	18 - 26	98507-05030	40 - 18								
	36 - 16		40 - 21								
95027-06025	33 - 17	98702-03020	40 - 10								
95027-08030	33 - 4	98907-05014	38 - 23								
95027-08035	38 - 26	99002-07600	12 - 32								
	39 - 4	99009-10400	14 - 27								
95302-06600	17 - 19	99009-12400	17 - 14								
95314-06600	28 - 24	99009-17400	17 - 9								
95317-08700	39 - 10	99009-52500	28 - 13								
95602-05200	39 - 6	99530-08012	6 - 5								
95602-06100	40 - 12		12 - 4								
	19 - 14		12 - 23								
95602-06200	21 - 5		41 - 25								
95602-16100	32 - 4	99530-08016	2 - 11								
95607-06100	32 - 21	99530-10116	11 - 5								
	40 - 8	99590-10114	12 - 39								
95612-08625	1 - 11										
95612-12630	28 - 17										
95614-12100	28 - 19										
95702-05500	39 - 18										
95702-12500	36 - 32										
95707-05500	19 - 8										
95707-06500	36 - 13										
	42 - 4										
95802-06010	24 - 47										
95812-06030	24 - 14										
95812-08020	19 - 2										
95812-08045	6 - 4										