

- LEGENDS**
1. Left Handlebar Controls Assembly
 2. Clutch Switch
 3. Headlight Dimmer Switch
 4. Horn Switch
 5. Turn Signal Switch
 6. Multi-Meter Assembly
 7. Water Temperature Gauge
 8. Tachometer
 9. Meter Lamp (3W x 2)
 10. High Beam Indicator Lamp (3W)
 11. Turn Signal Indicator Lamp (3W)
 12. Fuel Level Indicator Lamp (3W)
 13. Oil Level Warning Lamp (3W)
 14. Neutral Indicator Lamp (3W)
 15. Front Left Turn Signal Lamp (Parking/Running) (27W/8W)
 16. Headlight (Halogen 60W/55W)
 17. Front Right Turn Signal Lamp (Parking/Running) (27W/8W)
 18. Speedometer Assembly
 19. Meter Lamp (3W x 2)
 20. Reed Switch
 21. Right Handlebar Controls Assembly
 22. Start Switch
 23. Engine Stop Switch
 24. Fuel Reserve Switch
 25. Front Brake Lamp Switch
 26. Main Switch
 27. Ignitor Unit
 28. Thermo Switch
 29. Temperature Sender
 30. Radiator Fan Motor
 31. Rear Left Cylinder Ignition Coil (#1)
 32. Front Left Cylinder Ignition Coil (#2)
 33. Rear Right Cylinder Ignition Coil (#3)
 34. Front Right Cylinder Ignition Coil (#4)
 35. Spark Plug (NGK DPR8EA-9)
 36. Fuel Sender
 37. Rear Brake Lamp Switch
 38. Starter Motor
 39. Starter Relay
 40. Battery (Yusua BTY-YB16A-LA-20)
 41. Chassis Ground
 42. Fuse Box
 43. Ignition Fuse (10A)
 44. Signaling System Fuse (10A)
 45. Headlight Fuse (15A)
 46. Radiator Fan Motor Fuse (10A)
 47. Main Fuse (30A-BL x2)
 48. Rear Right Turn Signal Light (27W)
 49. Tail/Brake Lamp (27W/8W x 2)
 50. Rear Left Turn Signal Lamp (27W)
 51. Neutral Switch
 52. Oil Level Switch
 53. Rectifier/Regulator
 54. AC Magneto
 55. Pickup Coil Assy
 56. Sidestand Switch
 57. Fuel Pump
 58. Fuel Pump Relay
 59. Vacuum Pressure Sensor
 60. V-Boost Servo Motor
 61. V-Boost Valve Control Unit
 62. Turn Signal Relay
 63. Sidestand Relay
 64. Diode Assy
 65. Horn

- COLOR CODES**
- SOLID COLORS**
- B Black
 - Br Brown
 - Ch Chocolate
 - Dg Dark Green
 - G Green
 - Gr Gray
 - L Blue
 - O Orange
 - P Pink
 - R Red
 - Sb Sky Blue
 - W White
 - Y Yellow
- SOLID COLOR/STRIPE**
- B/R Black/Red
 - B/W Black/White
 - B/Y Black/Yellow
 - Br/W Brown/White
 - G/R Green/Red
 - G/Y Green/Yellow
 - L/B Blue/Black
 - L/W Blue/White
 - L/Y Blue/Yellow
 - R/G Red/Green
 - R/W Red/White
 - R/Y Red/Yellow
 - W/G White/Green
 - W/R White/Red
 - Y/R Yellow/Red

Note:
 (1) Black/White (B/W) (with Colored Tags) Wiring Diagram for those of you that hate those hard to read, "Color" Yamaha Wiring Diagrams and for the "Color Blind".
 (2) This Wiring Diagram is for the following U.S.A./Canada Models of the VMX12 (V-Max 1200cc)
 VMX12N/NC (1985) No V-Max (1987) VMX12U/UC (1988) VMX12S/SC (1986) VMX12W/WC (1989)

**1985-86, 1988-89
 Yamaha VMX1200 Series
 V-Max
 Wiring Diagram**

18 Feb 2011 v1.0_U1

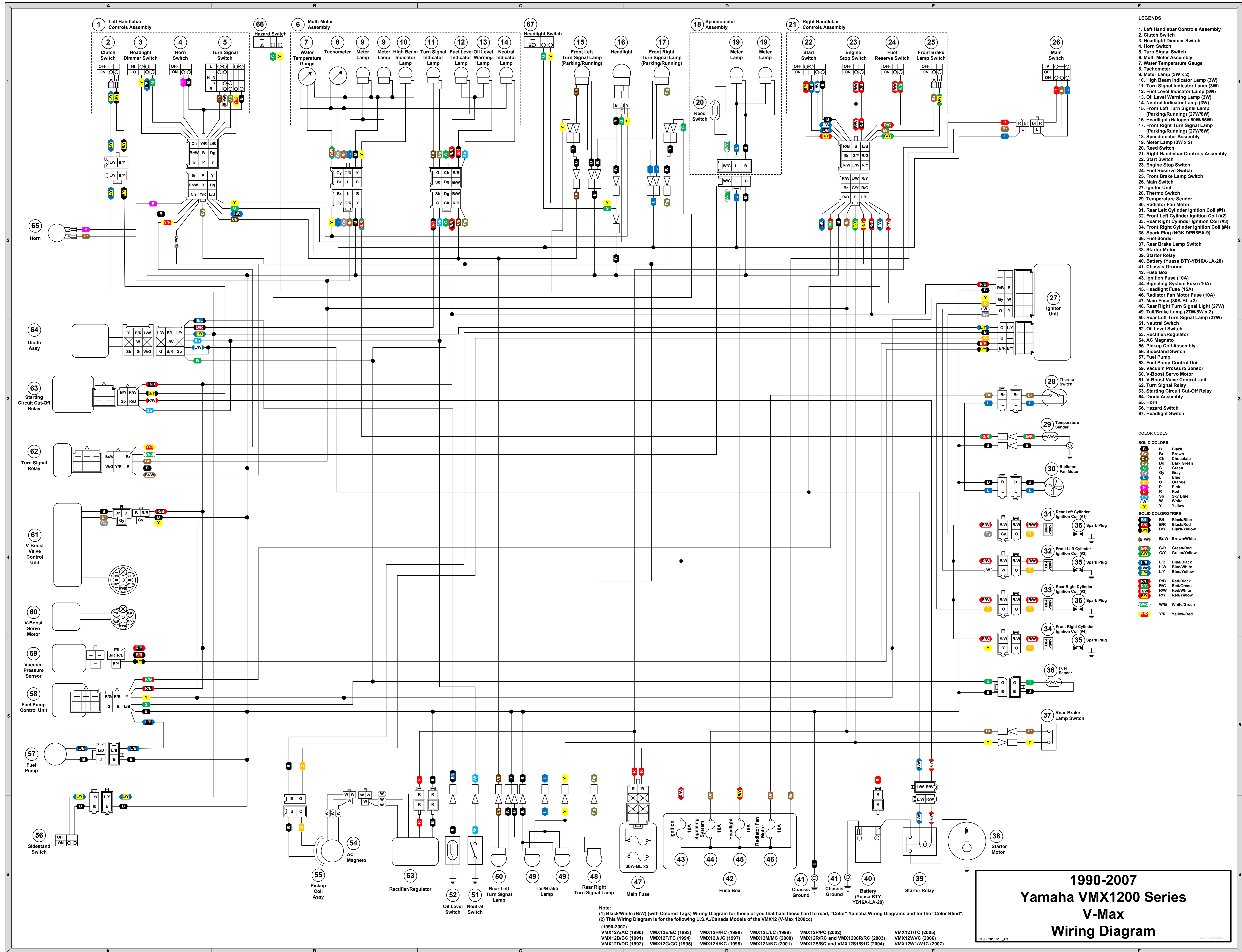

- LEGENDS**
1. Left Handlebar Controls Assembly
 2. Clutch Switch
 3. Headlight Dimmer Switch
 4. Horn Switch
 5. Turn Signal Switch
 6. Multi-Meter Assembly
 7. Water Temperature Gauge
 8. Tachometer
 9. Meter Lamp (3W x 2)
 10. High Beam Indicator Lamp (3W)
 11. Turn Signal Indicator Lamp (3W)
 12. Fuel Level Indicator Lamp (3W)
 13. Oil Level Warning Lamp (3W)
 14. Neutral Indicator Lamp (3W)
 15. Front Left Turn Signal Lamp (Parking/Running) (27W/8W)
 16. Headlight (Halogen 60W/55W)
 17. Front Right Turn Signal Lamp (Parking/Running) (27W/8W)
 18. Speedometer Assembly
 19. Meter Lamp (3W x 2)
 20. Reed Switch
 21. Right Handlebar Controls Assembly
 22. Start Switch
 23. Engine Stop Switch
 24. Fuel Reserve Switch
 25. Front Brake Lamp Switch
 26. Main Switch
 27. Ignitor Unit
 28. Thermo Switch
 29. Temperature Sender
 30. Radiator Fan Motor
 31. Rear Left Cylinder Ignition Coil (#1)
 32. Front Left Cylinder Ignition Coil (#2)
 33. Rear Right Cylinder Ignition Coil (#3)
 34. Front Right Cylinder Ignition Coil (#4)
 35. Spark Plug (NGK DPR8EA-9)
 36. Fuel Sender
 37. Rear Brake Lamp Switch
 38. Starter Motor
 39. Starter Relay
 40. Battery (Yusasa BTY-YB16A-LA-20)
 41. Chassis Ground
 42. Fuse Box
 43. Ignition Fuse (10A)
 44. Signaling System Fuse (10A)
 45. Headlight Fuse (15A)
 46. Radiator Fan Motor Fuse (10A)
 47. Main Fuse (30A-BL x2)
 48. Rear Right Turn Signal Light (27W)
 49. Tail/Brake Lamp (27W/8W x 2)
 50. Rear Left Turn Signal Lamp (27W)
 51. Neutral Switch
 52. Oil Level Switch
 53. Rectifier/Regulator
 54. AC Magneto
 55. Pickup Coil Assy
 56. Sidestand Switch
 57. Fuel Pump
 58. Fuel Pump Control Unit
 59. Vacuum Pressure Sensor
 60. V-Boost Servo Motor
 61. V-Boost Valve Control Unit
 62. Turn Signal Relay
 63. Starting Circuit Cut-Off Relay
 64. Diode Assy
 65. Horn
 66. Hazard Switch
 67. Headlight Switch

- COLOR CODES**
- SOLID COLORS**
- B Black
 - Br Brown
 - Ch Chocolate
 - Dg Dark Green
 - G Green
 - Gy Gray
 - L Blue
 - O Orange
 - P Pink
 - R Red
 - Sb Sky Blue
 - W White
 - Y Yellow
- SOLID COLOR/STRIPE**
- BL Black/Blue
 - BR Black/Red
 - BY Black/Yellow
 - BrW Brown/White
 - GR Green/Red
 - GY Green/Yellow
 - LB Blue/Black
 - LW Blue/White
 - LY Blue/Yellow
 - RB Red/Black
 - RG Red/Green
 - RW Red/White
 - RY Red/Yellow
 - WG White/Green
 - YR Yellow/Red

Note:
 (1) Black/White (B/W) (with Colored Tags) Wiring Diagram for those of you that hate those hard to read, "Color" Yamaha Wiring Diagrams and for the "Color Blind".
 (2) This Wiring Diagram is for the following U.S.A./Canada Models of the VMX12 (V-Max 1200cc) (1990-2007)
 VMX12A/JC (1990) VMX12E/EC (1993) VMX12H/HC (1996) VMX12L/LC (1999) VMX12P/PC (2002) VMX12T/TC (2005)
 VMX12B/BC (1991) VMX12F/FC (1994) VMX12J/JC (1997) VMX12M/MC (2000) VMX12R/RC and VMX1200R/RC (2003) VMX12V/VIC (2006)
 VMX12D/DC (1992) VMX12G/GC (1995) VMX12K/KC (1998) VMX12N/NC (2001) VMX12S/SC and VMX12S1/S1C (2004) VMX12W1/W1C (2007)

**1990-2007
 Yamaha VMX1200 Series
 V-Max
 Wiring Diagram**

20 July 2016 v1.0_U3

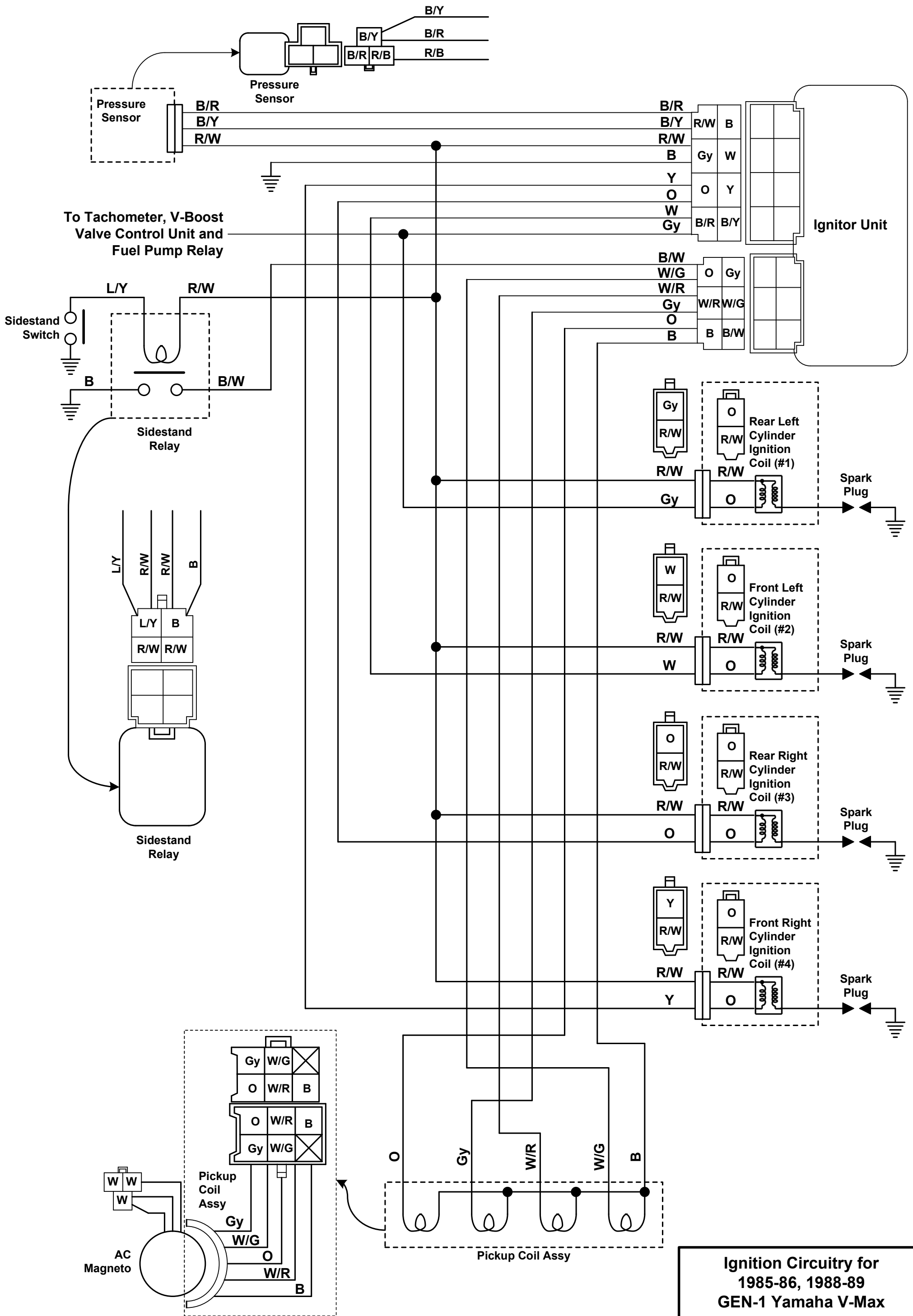

**Ignition Circuitry for
1985-86, 1988-89
GEN-1 Yamaha V-Max**

15 February 2018 v1.0_U1 (c) 2018 cvvmax

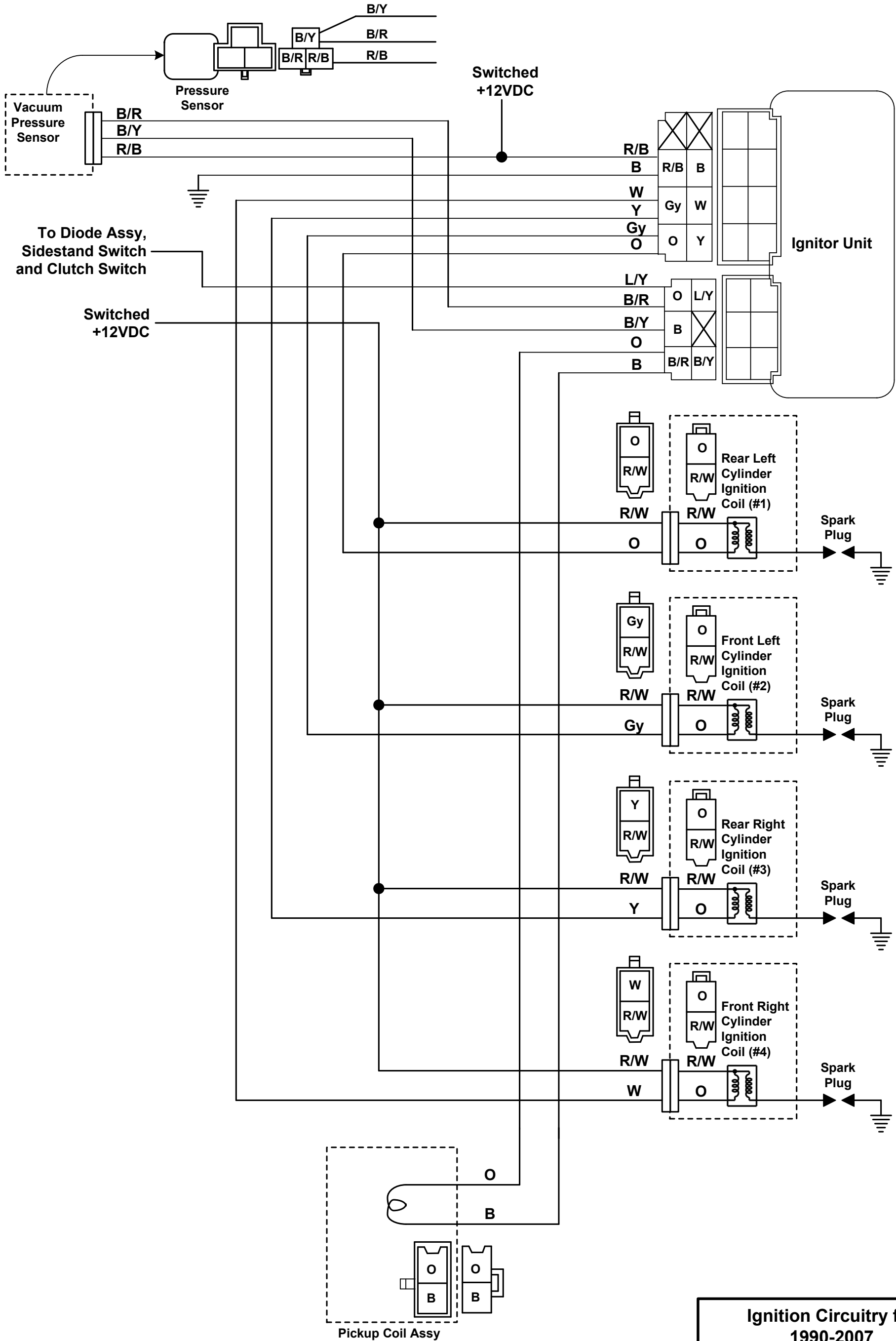

**Ignition Circuitry for
1990-2007
GEN-1 Yamaha V-Max**